



# SeceuroGlide Sectional Elite Installation Instructions - Wicket Door

.....  
Please read these instructions carefully prior to commencing the installation of the door.

## **IMPORTANT SAFETY RULES**

This equipment must be installed and used in accordance with these instructions. Failure to follow these instructions could result in damage to the integrity of the safety circuits.

Two persons are required to install this product to ensure safe handling procedures.

### **CAUTION**

Do not wear rings, watches or loose clothing while installing or servicing the unit and ensure correct PPE is worn.

To avoid serious personal injury from entanglement, remove any loose objects from the equipment prior to operating door.

### **DANGER**

Installation and wiring must be in accordance with your local building and electrical regulations.

Any electrical work must be carried out by a suitably qualified person, if in doubt consult a qualified electrician.

Use only the mains lead supplied with the Remote Control Unit as failure to do so will invalidate the warranty.

Connect the mains lead to an adjacent 13 amp 3 pin switched socket. The plug must be fitted with a 13 amp fuse.

Note: For optimum electrical safety this unit should be connected to circuit protected by a R.C.D. (max 30 mA trip rating).

This unit should not be installed in a damp or wet space or on a damp or single skinned wall without sufficient spacers.

### **DANGER**

Disconnect electric power to the control unit before making repairs or removing covers.

Install the operator and/or Switch Control in a location where the garage door is visible, but out of the reach of children. The door must be in direct sight of the control and must not be operated via security or doorbell cameras. Do not allow children to operate push button(s) or remote control(s). Serious personal injury from a closing garage door may result from misuse of the operator.

### **CAUTION**

Activate unit only when the door is in full view, free of obstructions and operator is properly adjusted. No one should enter or leave the garage while the door is in motion. Do not allow children to play near the door.

Any modifications or improvements of this closure must be compliant with the standard BS EN 13241:2003+A2:2016. In this case, a "modification/transformation" file must be created by the installer as per the standard BS EN 23635:2002+A1:2008.

Considerable force is exerted by the extension springs. Carry out work in accordance with the safety instructions. Use the appropriate tools to install these products. Ensure that all work is carried out on a stable floor.

All the requirements of the standards BS EN 13241:2003+A2:2016 must be met and verified if necessary.

## **01. PRE-INSTALLATION**

Always check on delivery that the order details are correct and the door is undamaged, especially before removing any existing doors.

### Sequence of Installation & Contents

- 01. Pre-Installation Check
- 02. Fitter's Information Pack
- 03. Equipment Needed for Installation
- 04. Kit Contents for Each Door Configuration
- 05. Reveal Fix - Executive Framing Option
- 06. Vertical Rail Installation
- 07. Horizontal Rail Installation
- 08. Panel Assembly
- 09. Wicket Door Assembly
- 10. Final Adjustments & Optional Extras
- 11. Set the Limits
- 12. Commissioning
- 13. Technical Assistance

## PRE-INSTALLATION CHECK

**Note:** In case of power failure a manual system is fitted as standard but this can only be operated from inside the garage. If the garage has no service entrance door then an exterior release kit must be fitted to allow manual operation of the garage door from outside.

**Before removing the old door** check that the door size and colour correspond with that which was ordered.

### Structural Condition of Opening

- i. Ensure the area around the opening is strong enough to support the weight of the door.
- ii. The surface where the door is to be fitted must be flush and reasonably smooth. Small irregularities in the brickwork will be acceptable.
- iii. No obstacles in fitting footprint eg. no sharp objects, pipes, cables, bumps etc. sticking out from the pillars, lintel or header.
- iv. The lintel must not protrude backwards or forwards from the brick piers. Should the lintel protrude backwards or forwards from the brick piers this will require special instructions, please consult your supplier.
- v. The floor must be flat/level. If necessary install a sub-frame to ensure secure, flush and level fixing (recommended minimum 70 X 70 PAR). The lintel must not protrude backwards or forwards from the brick piers. Should the lintel protrude backwards or forwards from the brick piers this will require special instructions, please consult your installer.

### Fitting Notes

- vi. It is recommended that 2 people are available for fitting all door sizes.
- vii. The door must be fitted square and level, irrespective of the shape of the opening; on no account should any compensation be made to suit an irregular opening.
- viii. Ensure all necessary tools are to hand before starting.
- ix. The door package and its contents should be checked for obvious damage before removal of the wrapping.

**IF THERE IS ANY DAMAGE YOUR SUPPLIER SHOULD BE CONTACTED IMMEDIATELY.**

- x. Ensure there is a suitable 13 amp 3 pin switched socket adjacent to where the operator is to be fitted.
- xi. Ensure all tools and door components are gathered together inside the garage prior to starting the installation.

## 02. FITTER'S INFORMATION PACK

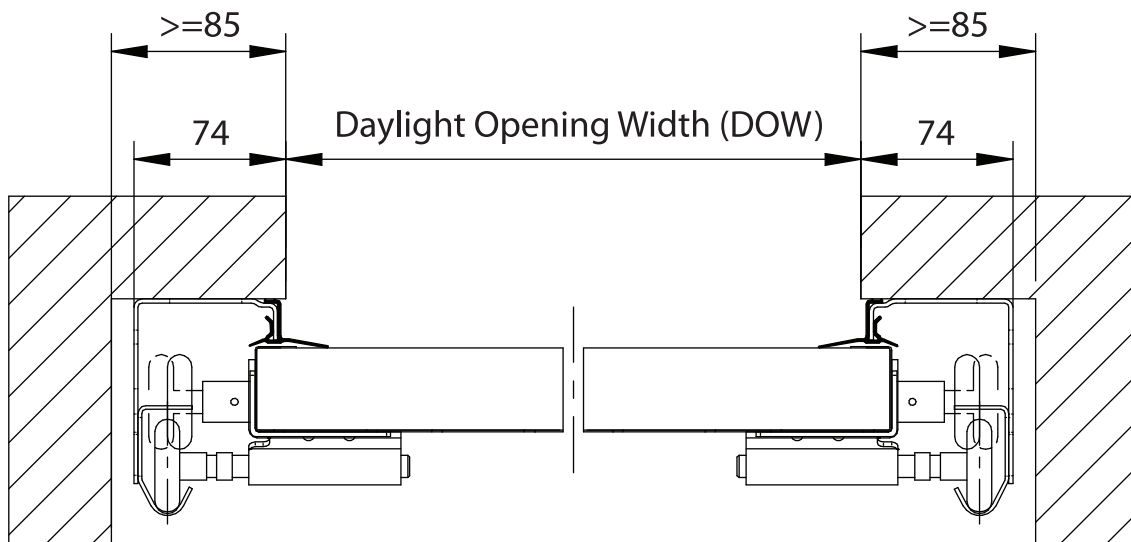
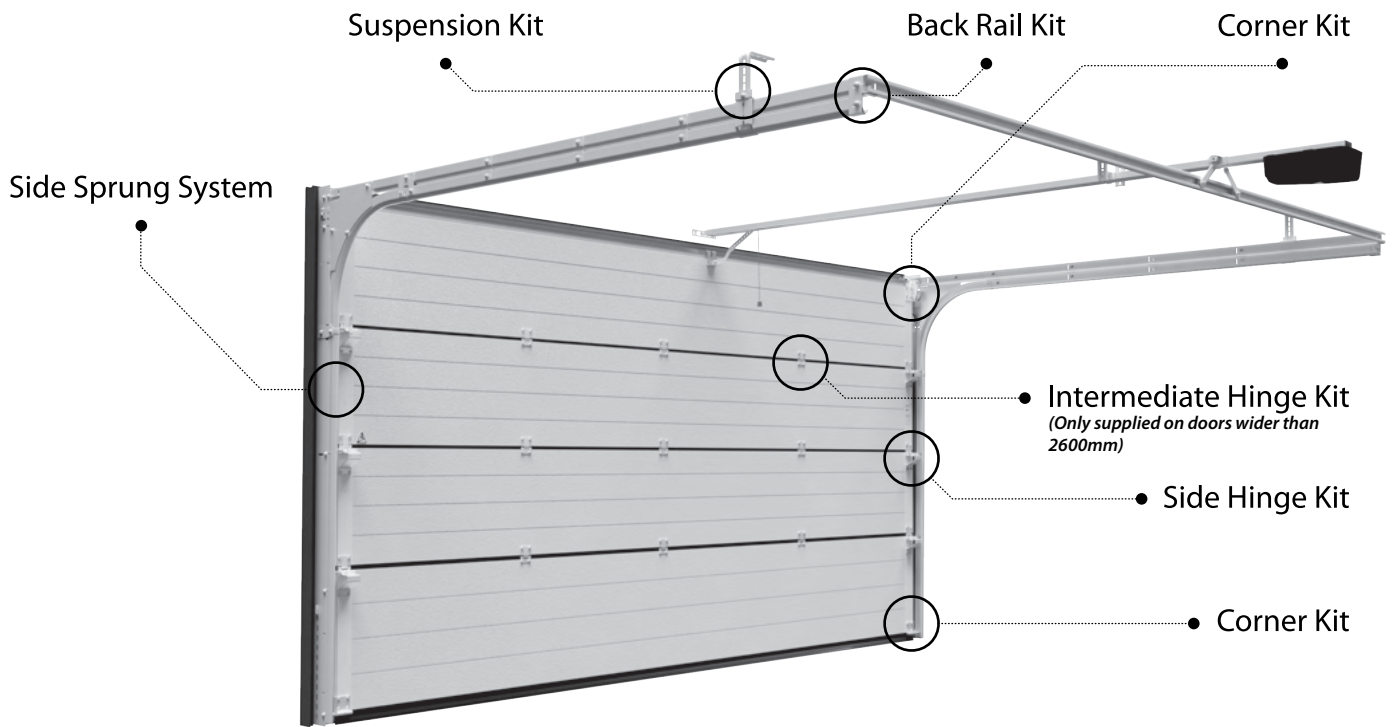

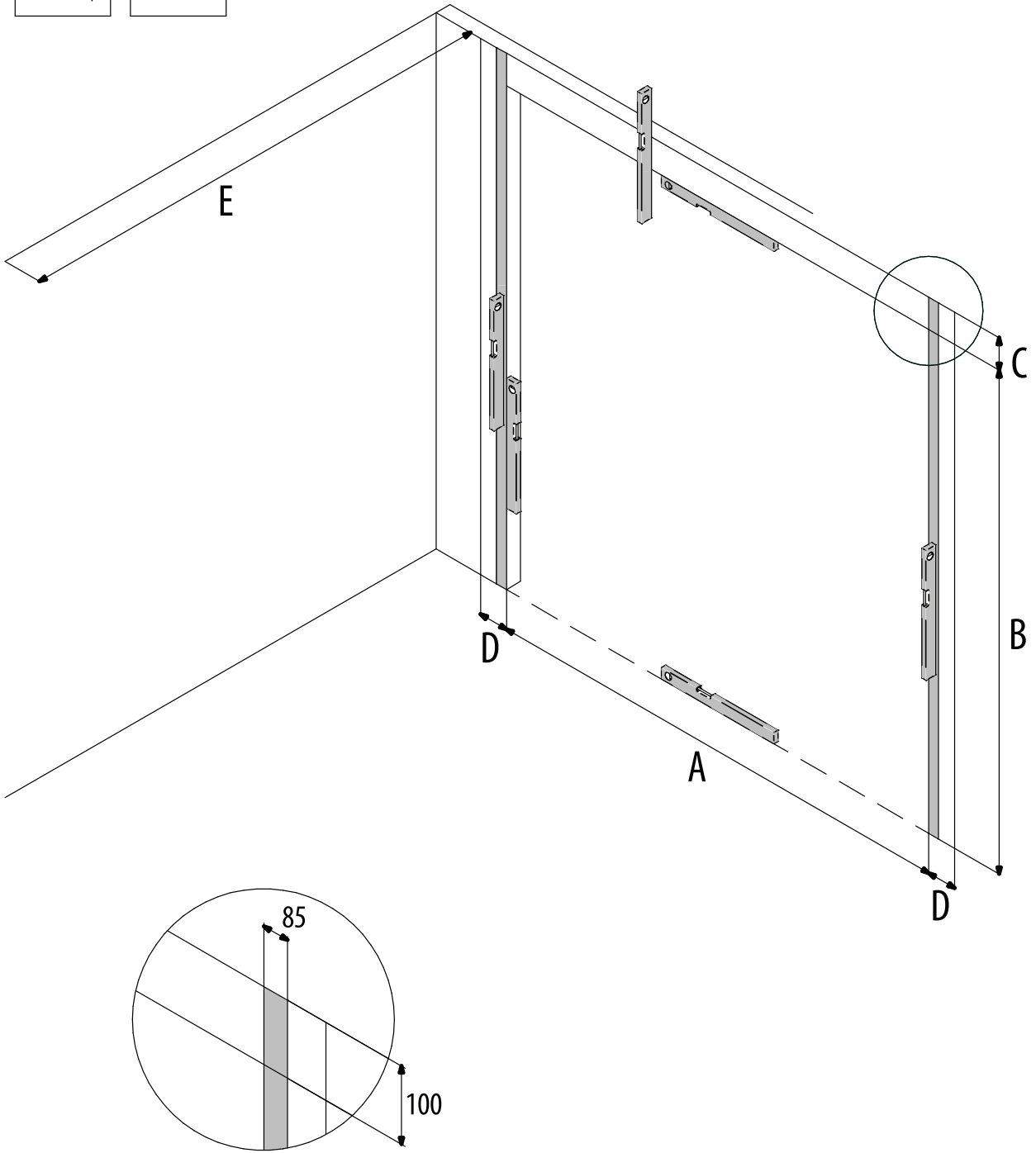
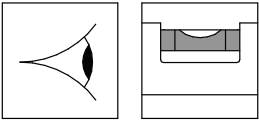

A	B	C	D	E
DLW	DLH	FLW	FSR	FMD
Daylight Width	Daylight Height	Free Head Room	Free Side Room	Free Mounting Dept

### 03. EQUIPMENT NEEDED FOR INSTALLATION

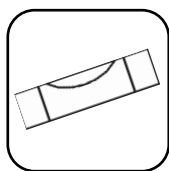

Spirit level

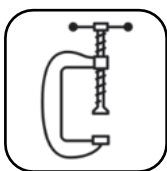

Clamp



Laser level



Plumb bob

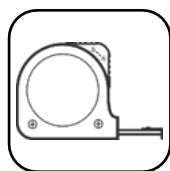

Tape measure



Utility knife



Electric screwdriver



10 and  
Socket



Pozi bit



10 and  
Flat wrench



3  
Allen key

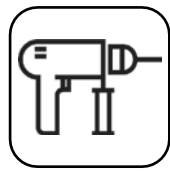

Hammer drill



30  
Torx bit



Ladder



Phillips screwdriver



Flat screwdriver



Pencil



Grinder



Combination pliers



Crimping pliers



Locking pliers



Steel drill bit  
Ø2-4.2-4.5-10-13



Hammer



Rivet gun



Hacksaw



Silicone sealant



Grease spray

# 04. KIT CONTENTS FOR EACH DOOR CONFIGURATION

## KIT CONTENTS FOR MOTORISED AND MANUAL DOORS

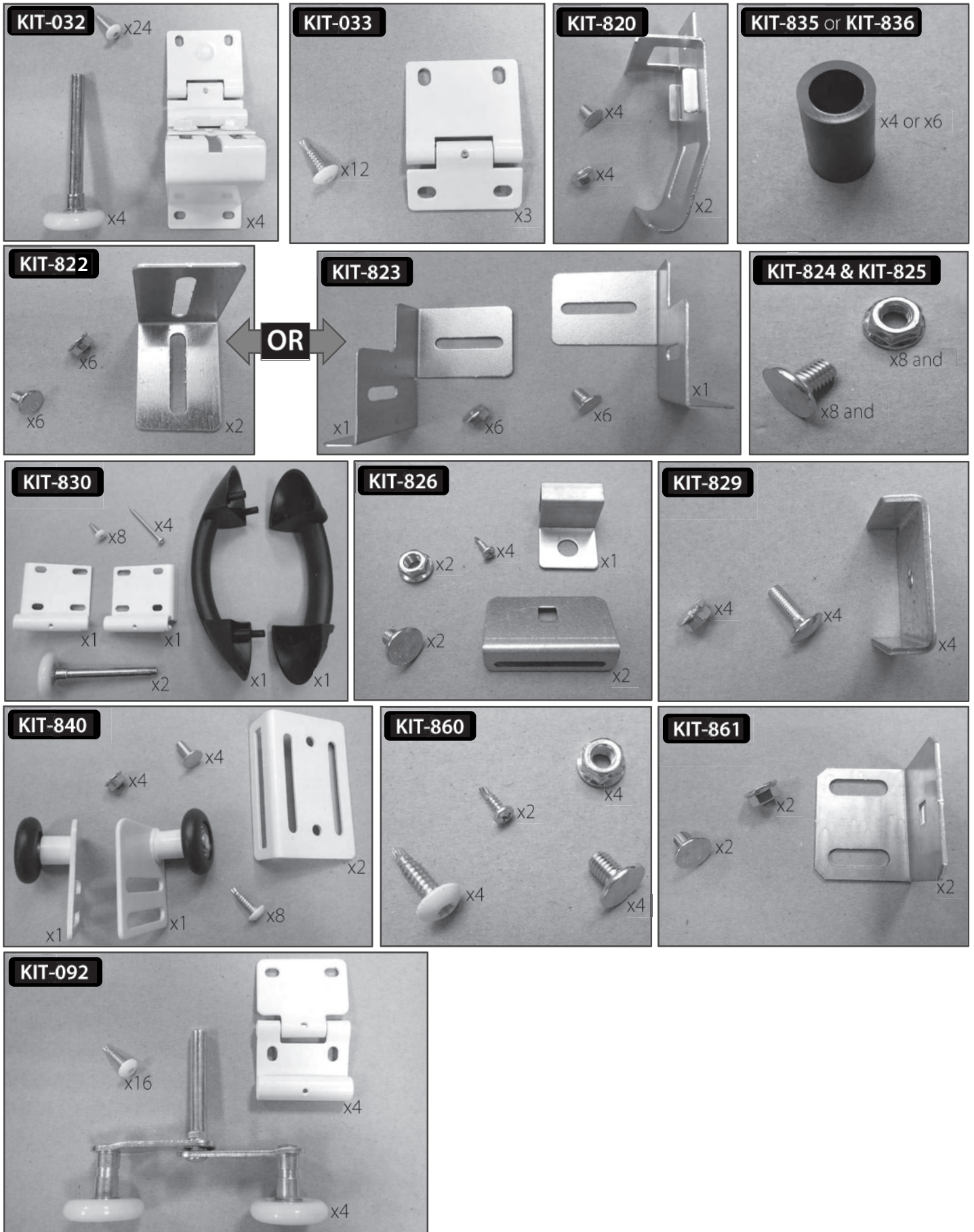

## KIT CONTENTS FOR MOTORISED DOORS

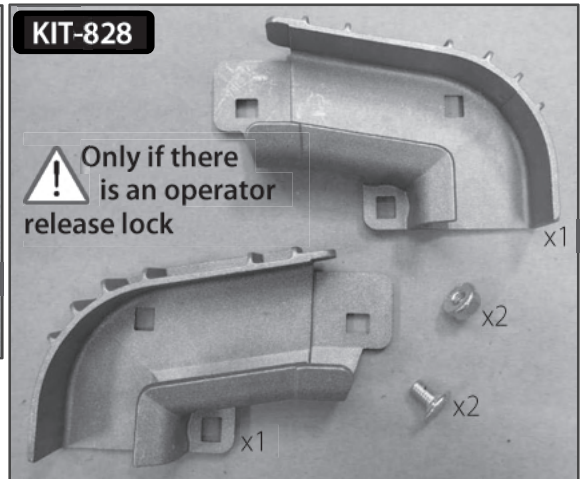
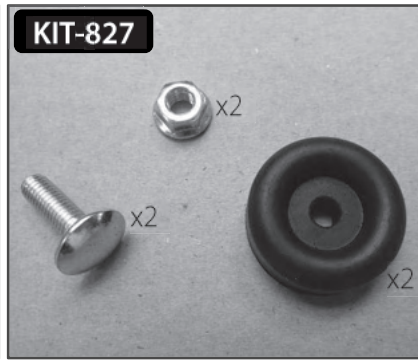
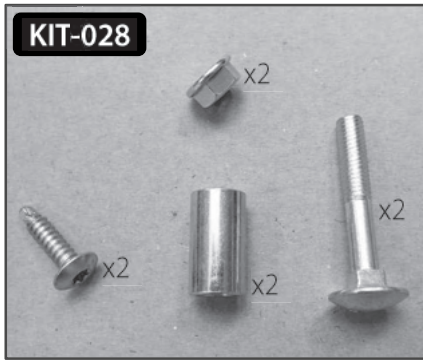

## KIT CONTENTS FOR MANUAL DOORS

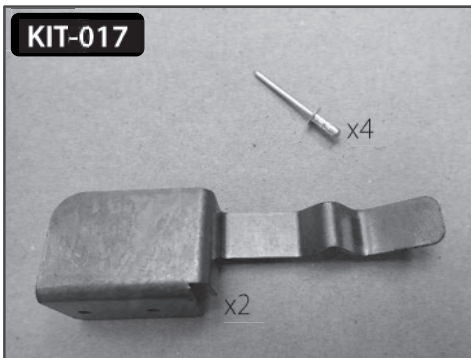
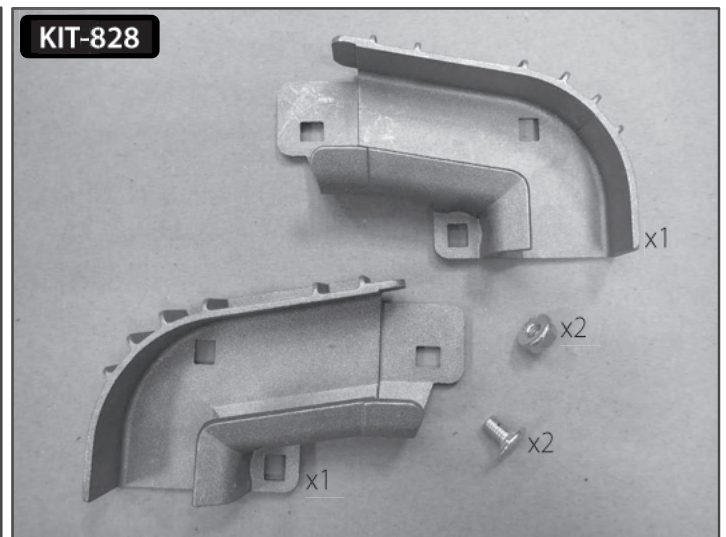

# KIT CONTENTS FOR WICKET DOORS

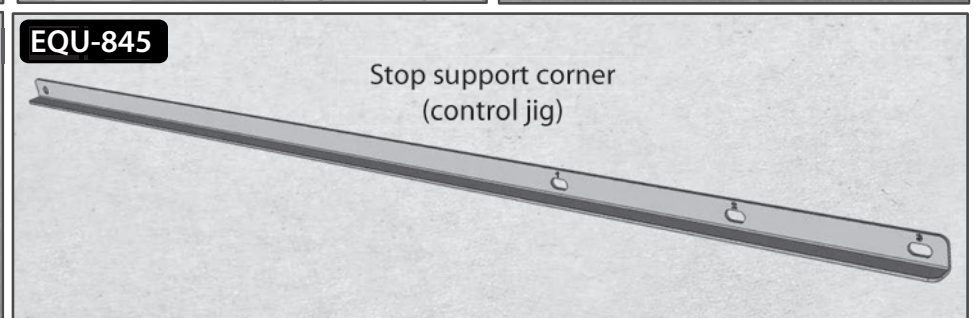
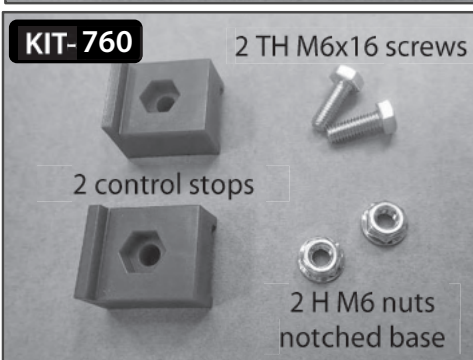
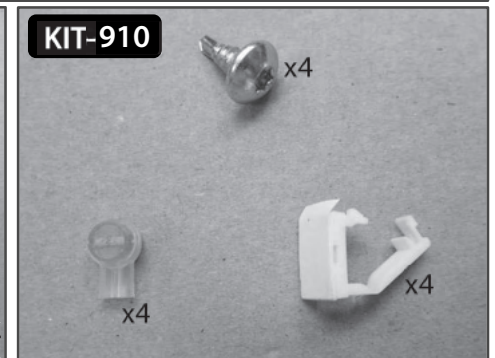
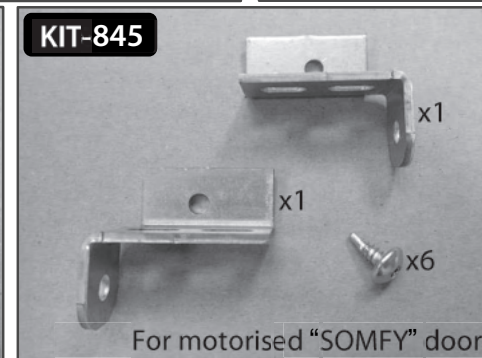
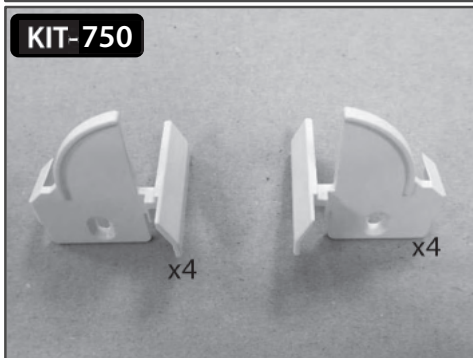
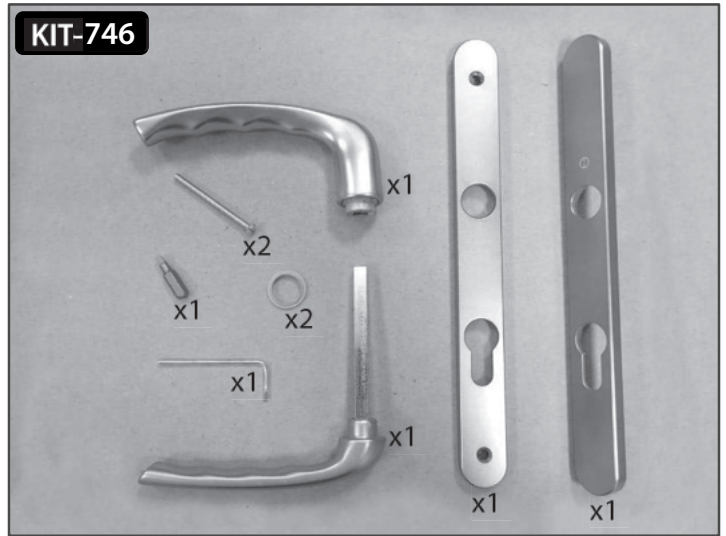
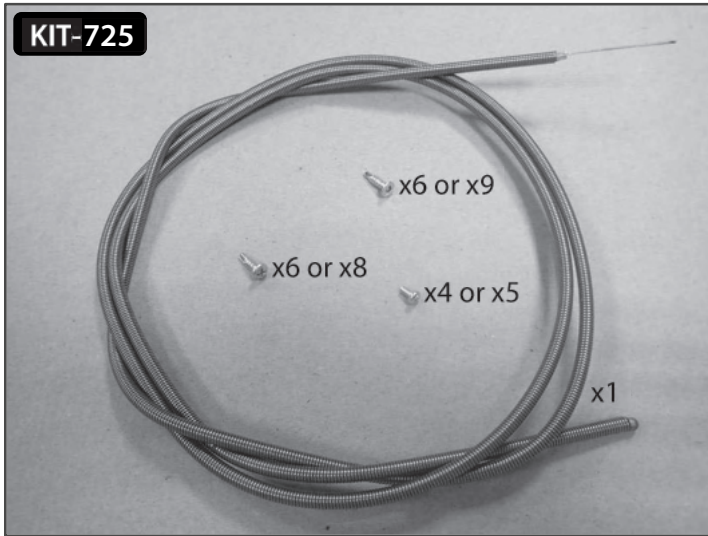



# 05. REVEAL FIX - EXECUTIVE FRAMING KIT OPTION

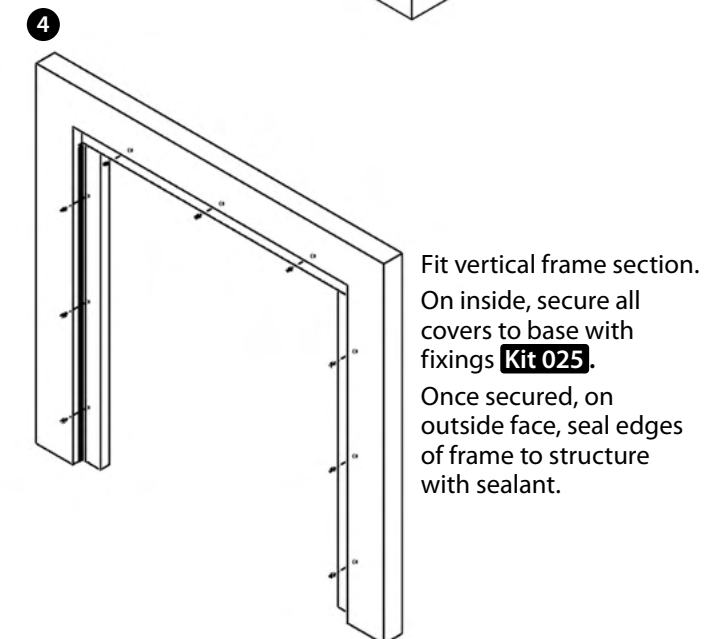
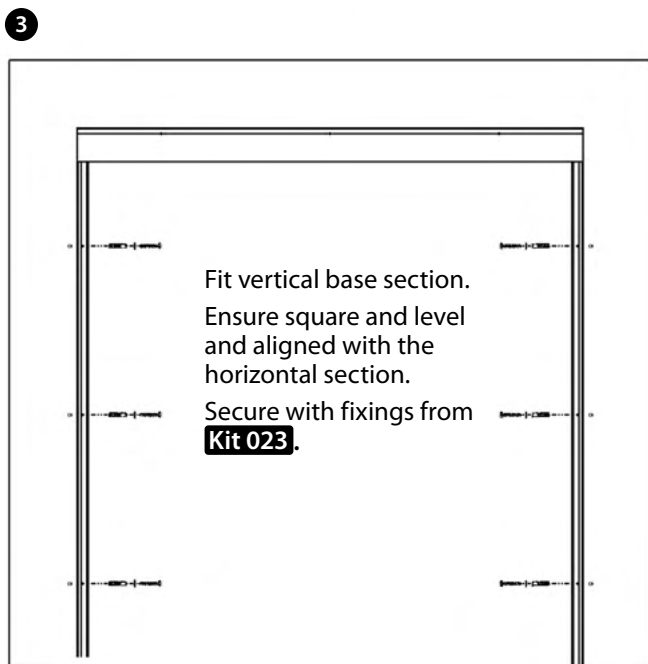
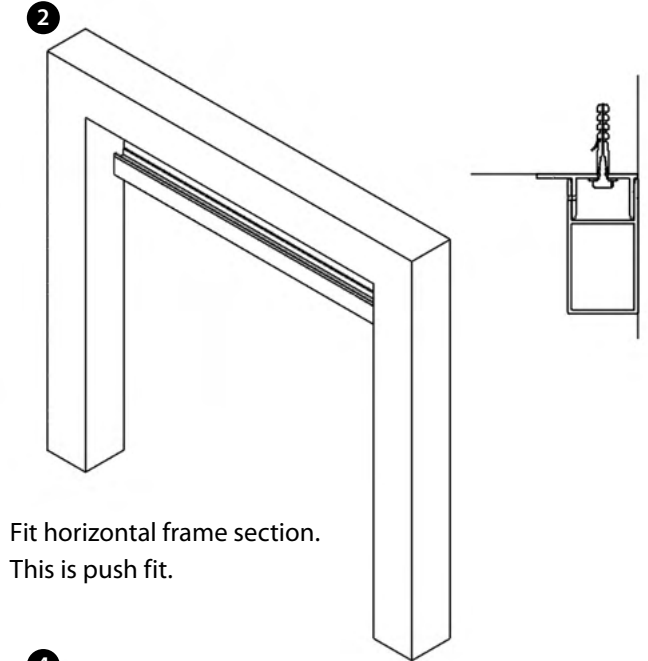
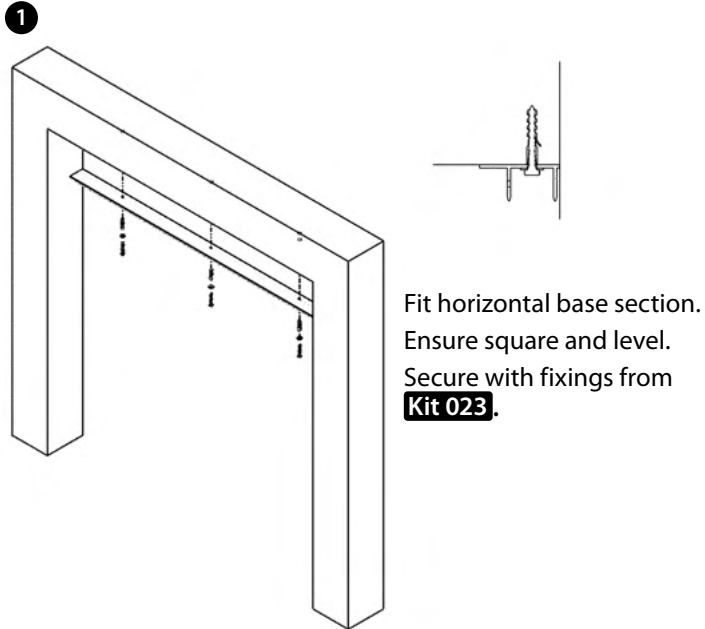
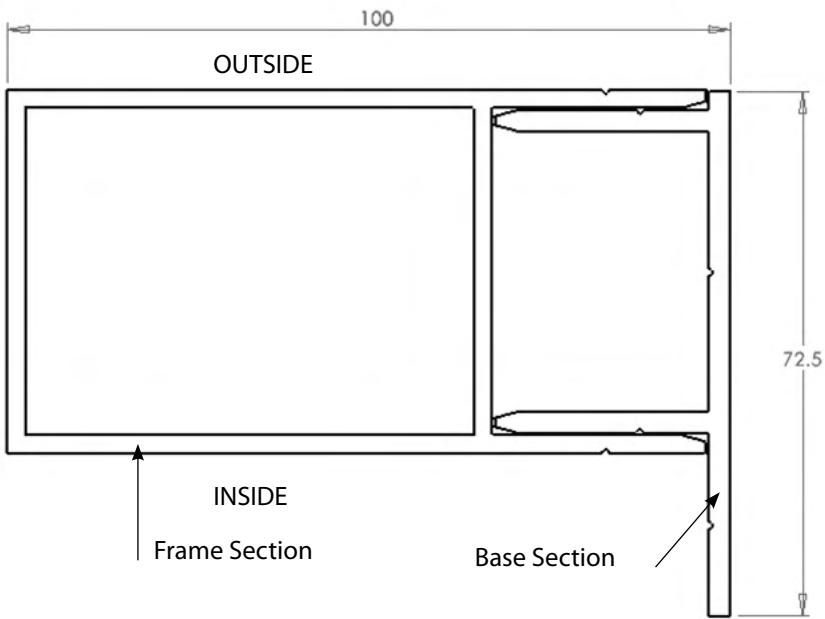

## 06. VERTICAL RAIL INSTALLATION

### CHECKING THE OPENING

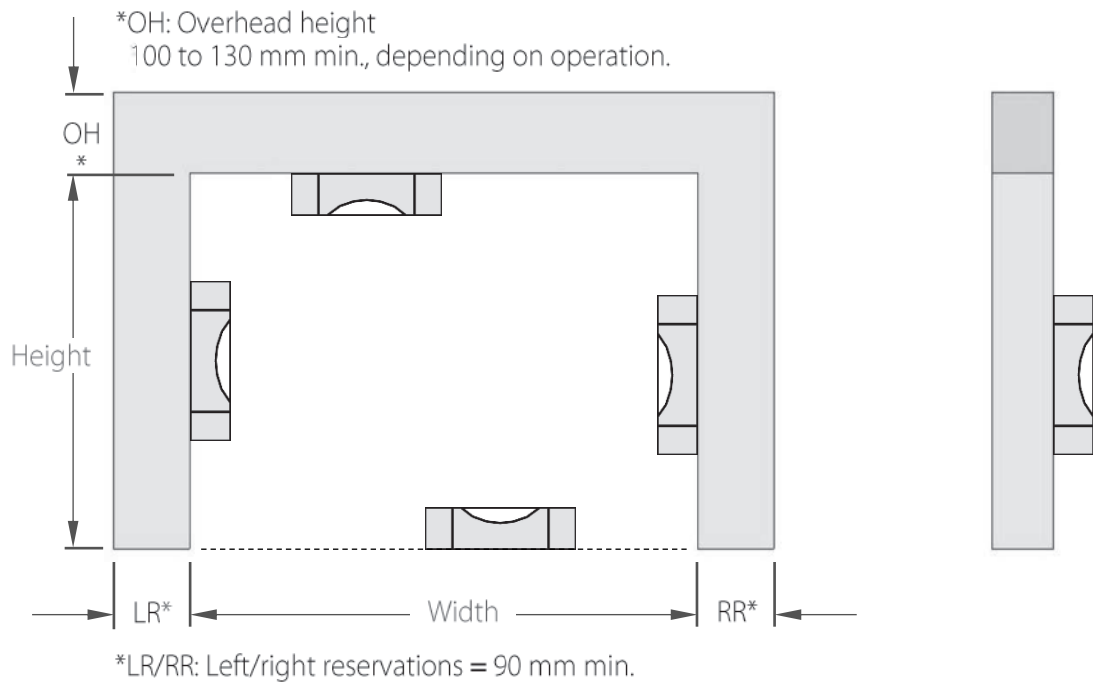
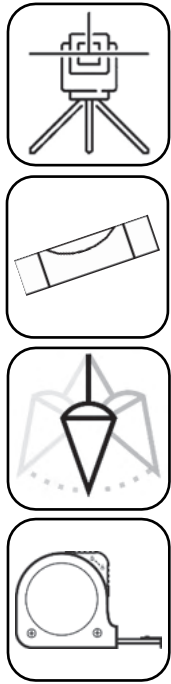

### ASSEMBLING THE VERTICAL RAIL

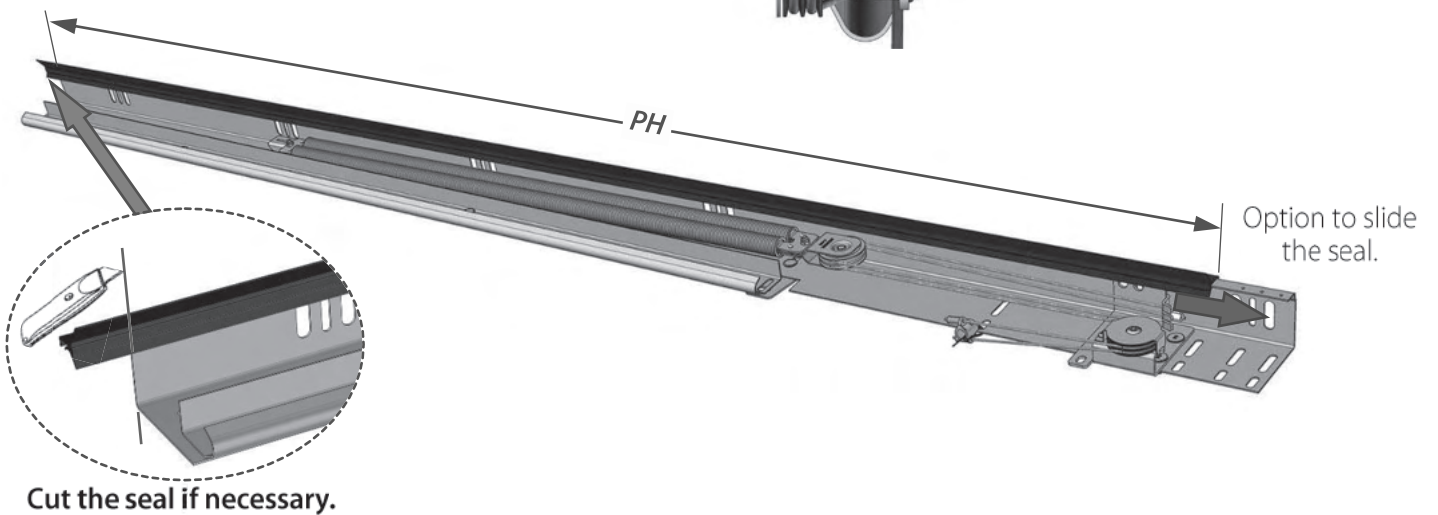
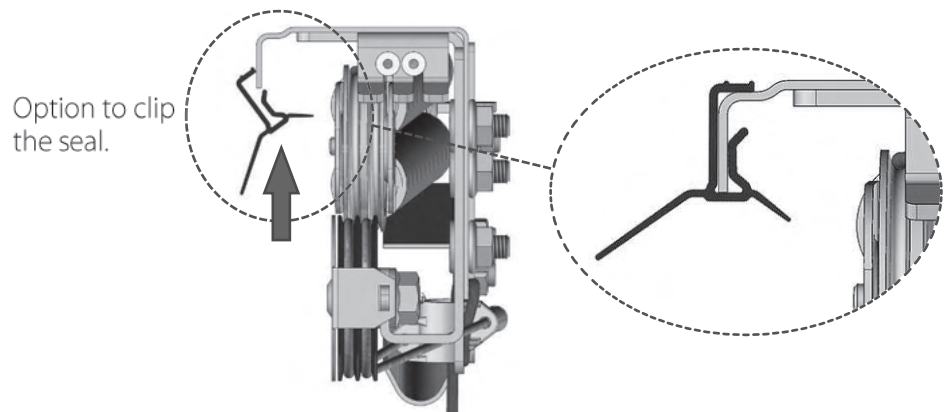

## CHECKING THE CABLES/SPRINGS

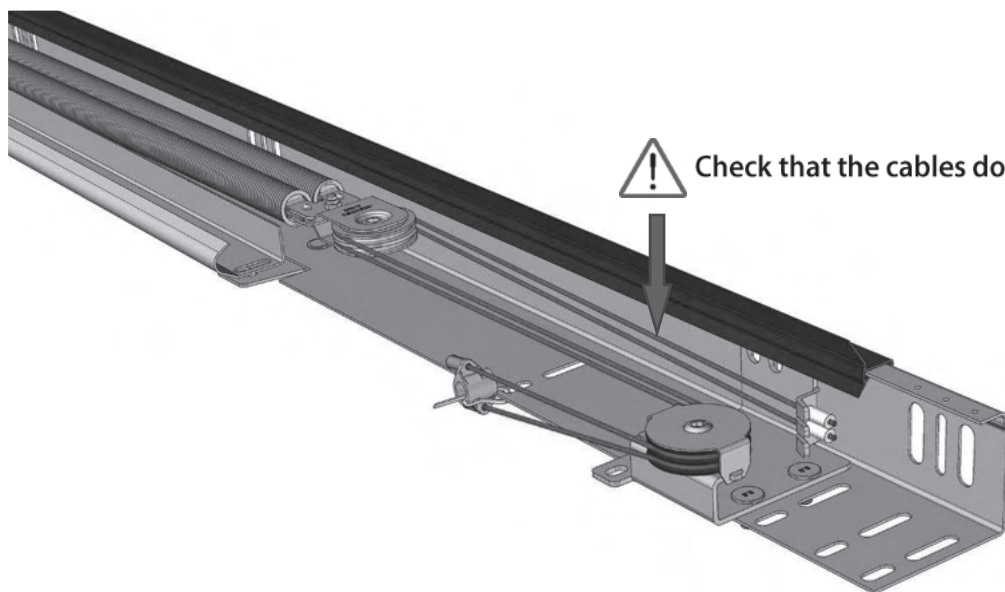
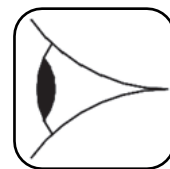

## ASSEMBLING THE FASCIA SEAL

Remove the protective film before assembling the seal.

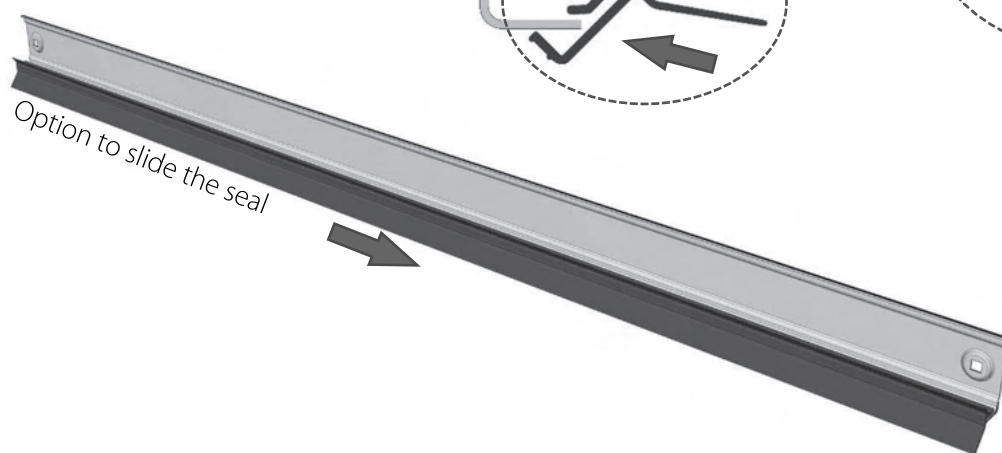
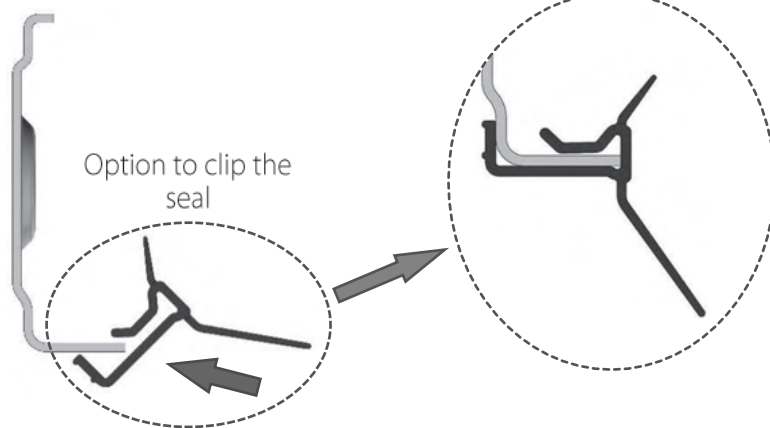

## ASSEMBLING THE FASCIA

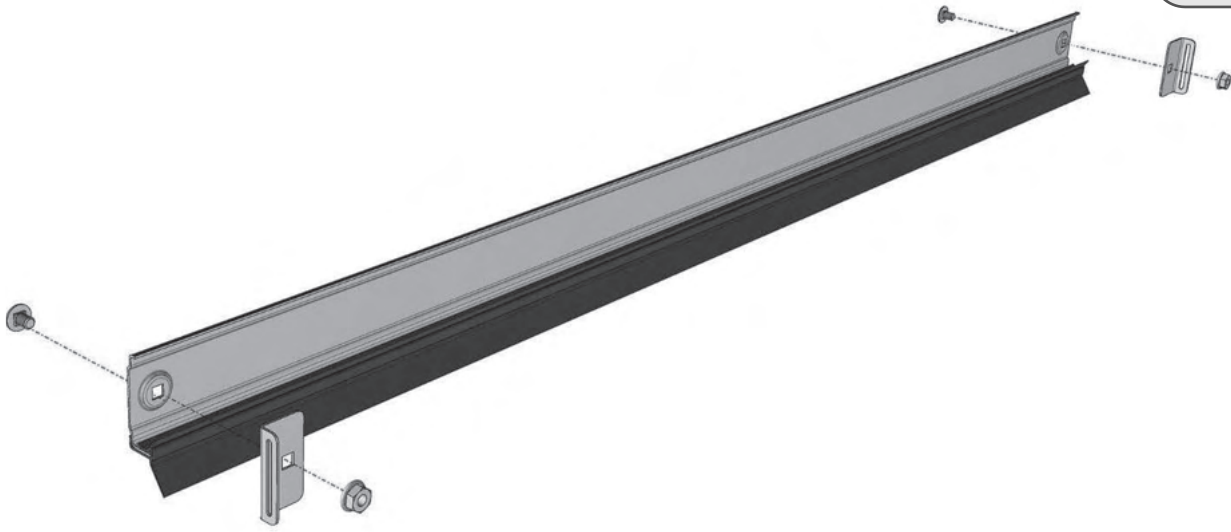
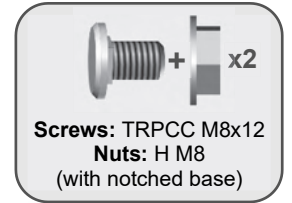
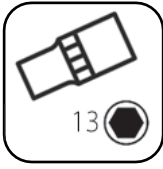
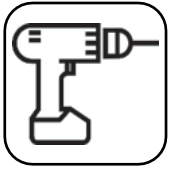

## REVEAL BRACKETS

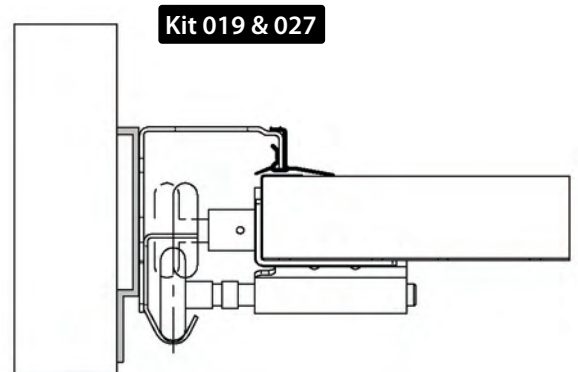
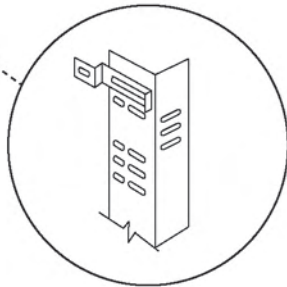

Position 5 brackets per side.  
Secure each bracket with 2 M8 x 18  
bolts and m8 serrated nuts.

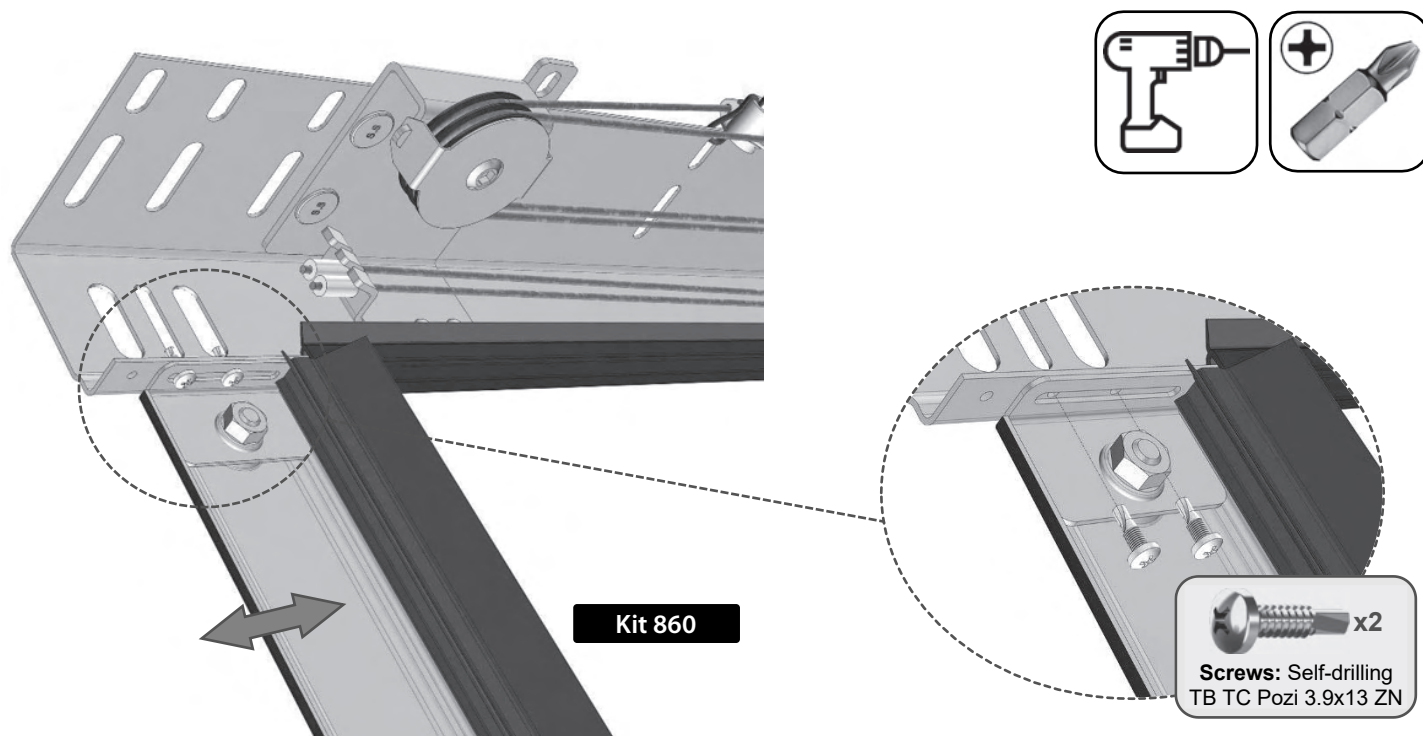

The vertical position of the fascia will be adjusted once the rails have been mounted on the wall.

**Repeat the process with the other vertical rail.**

## LAYOUT OF THE FRAME

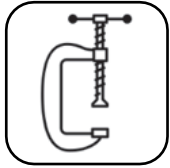
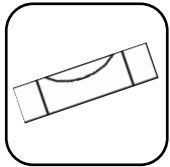

The back bar must be in contact with the backstop.

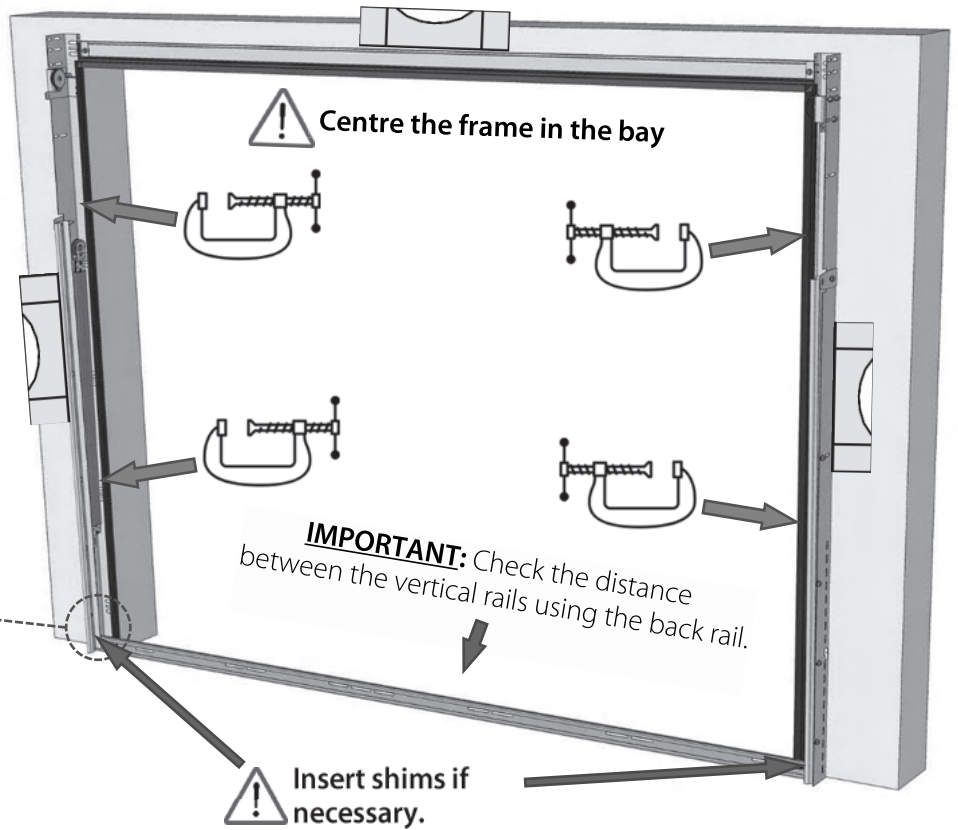
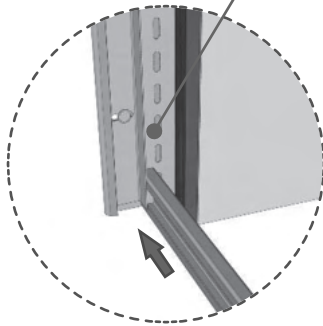

## FIXING THE VERTICAL RAILS

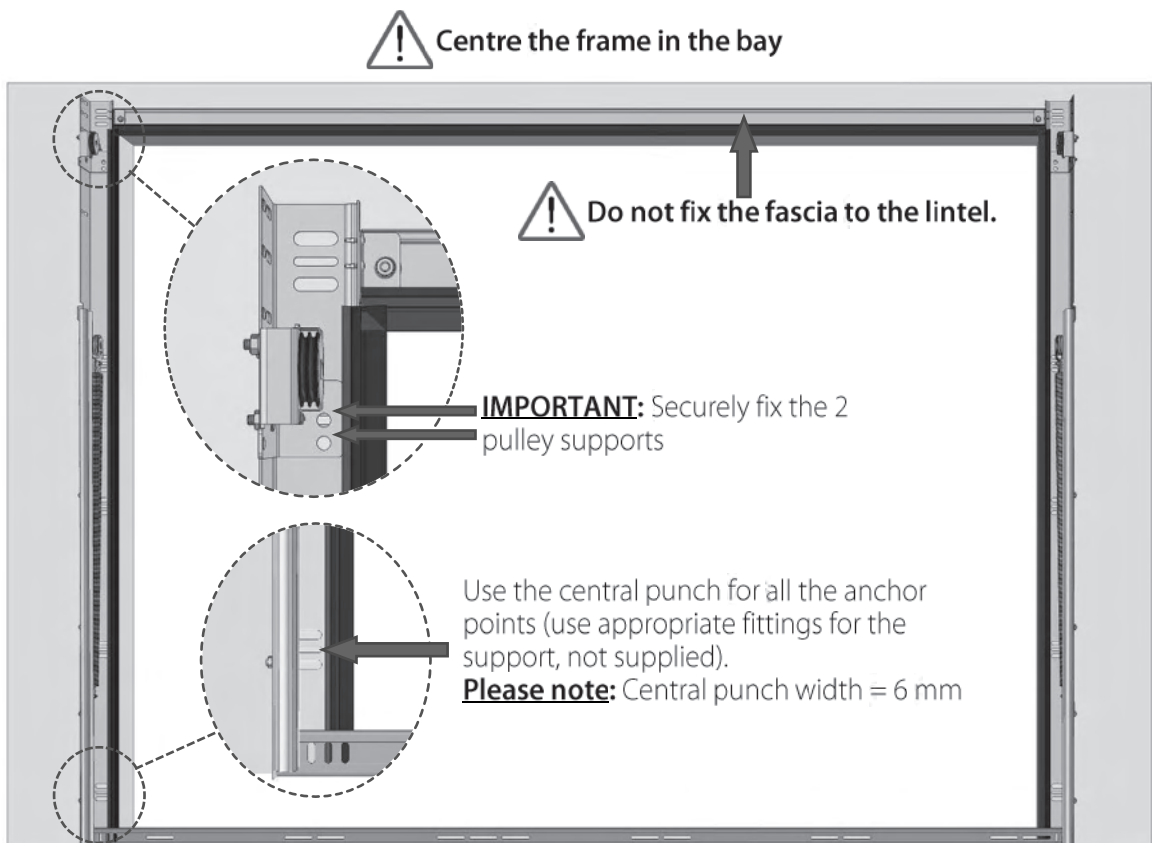
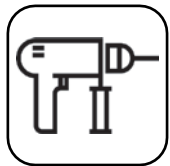

Repeat the process on the opposite side.

## 07. HORIZONTAL RAIL INSTALLATION

### ASSEMBLING THE STOPS (MOTORISED DOORS)

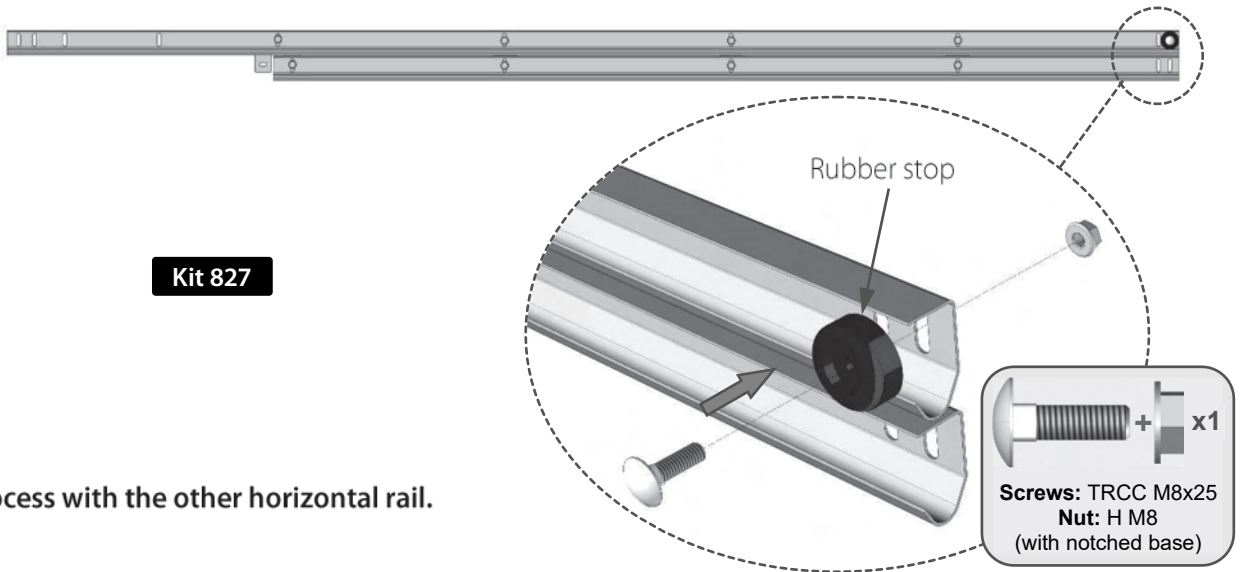
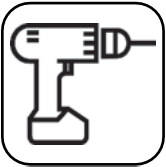

Repeat the process with the other horizontal rail.

### ASSEMBLING THE CURVES

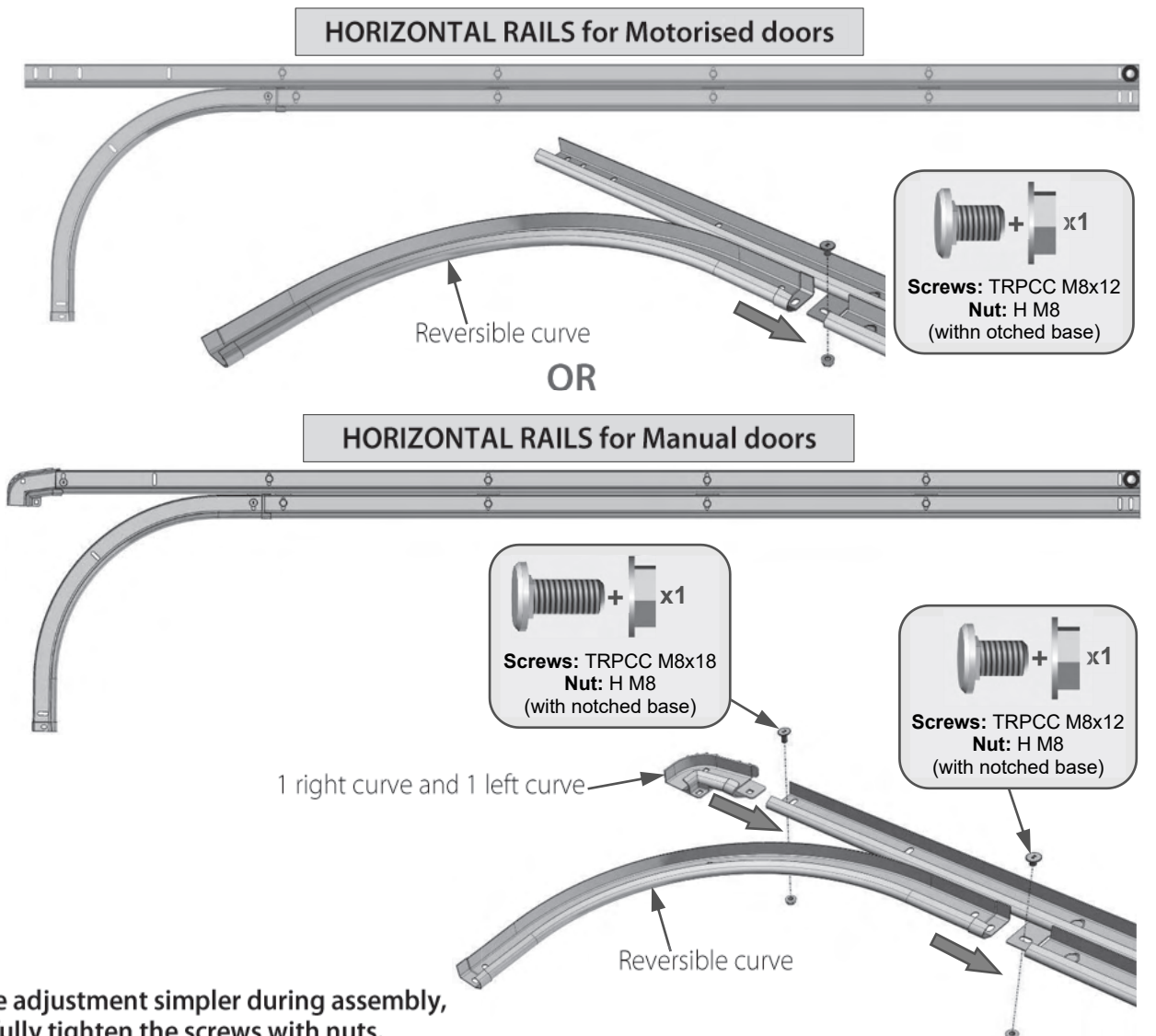
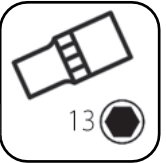
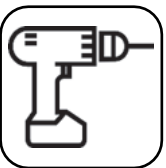

# FIXING THE HORIZONTAL RAILS

**MOTORISED door**

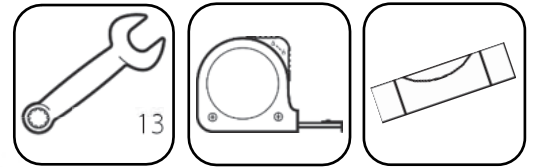

13

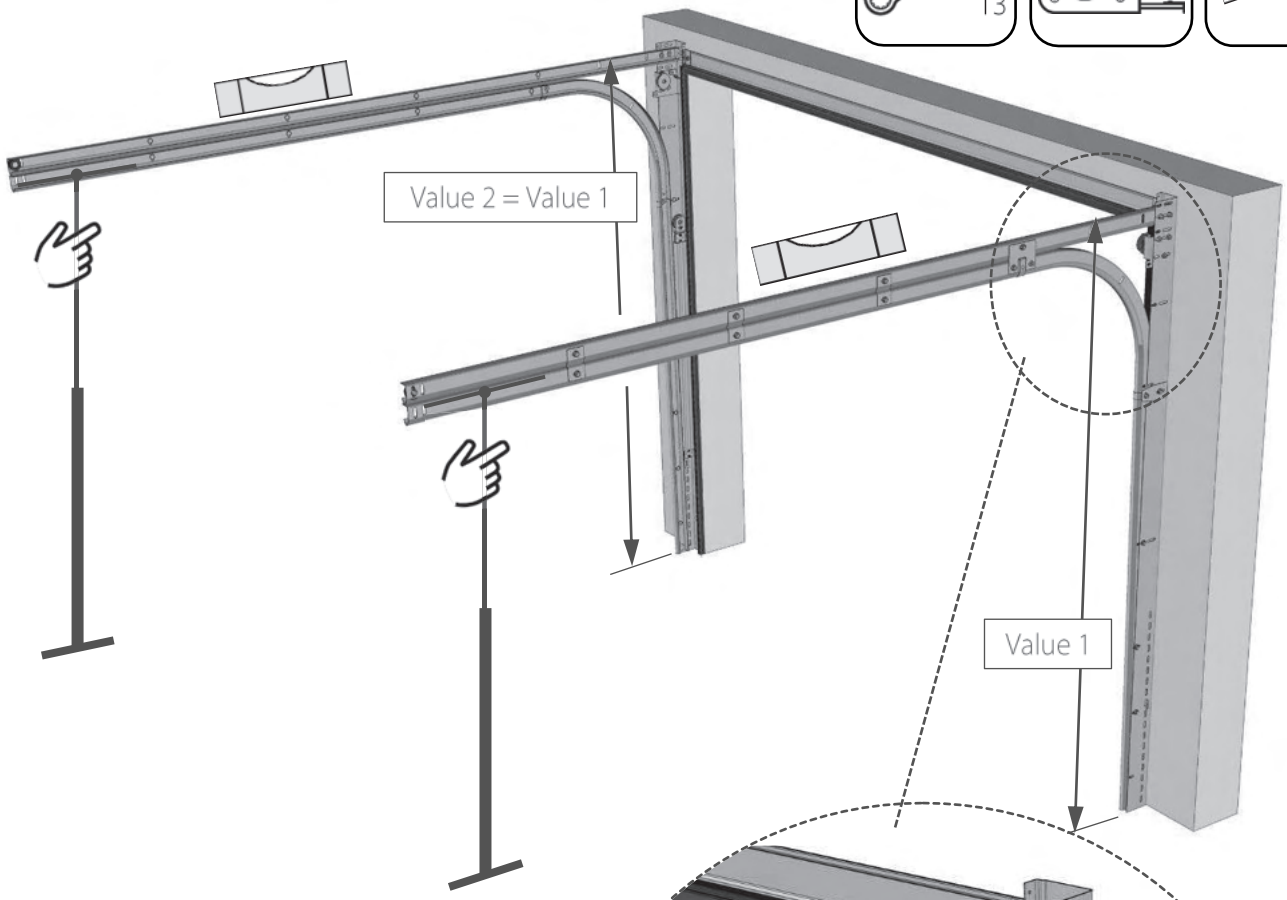

**Kit 824 & 825**

**REINFORCEMENT**  
Door > 100 kg

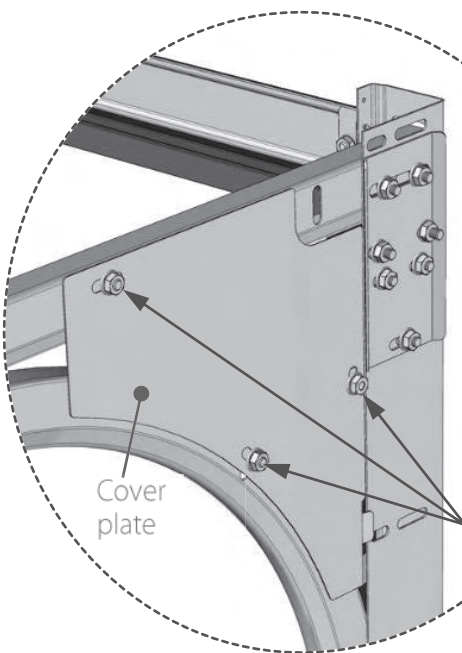

Cover plate

**Screws: TRPCC M8x12**  
**Nuts: H M8**  
(with notched base) x3

**Screws: TRPCC M8x12**  
**Nut: H M8**  
(with notched base) x1

**Screws: TRPCC M8x18**  
**Nuts: H M8**  
(with notched base) x2



**MANUAL door**

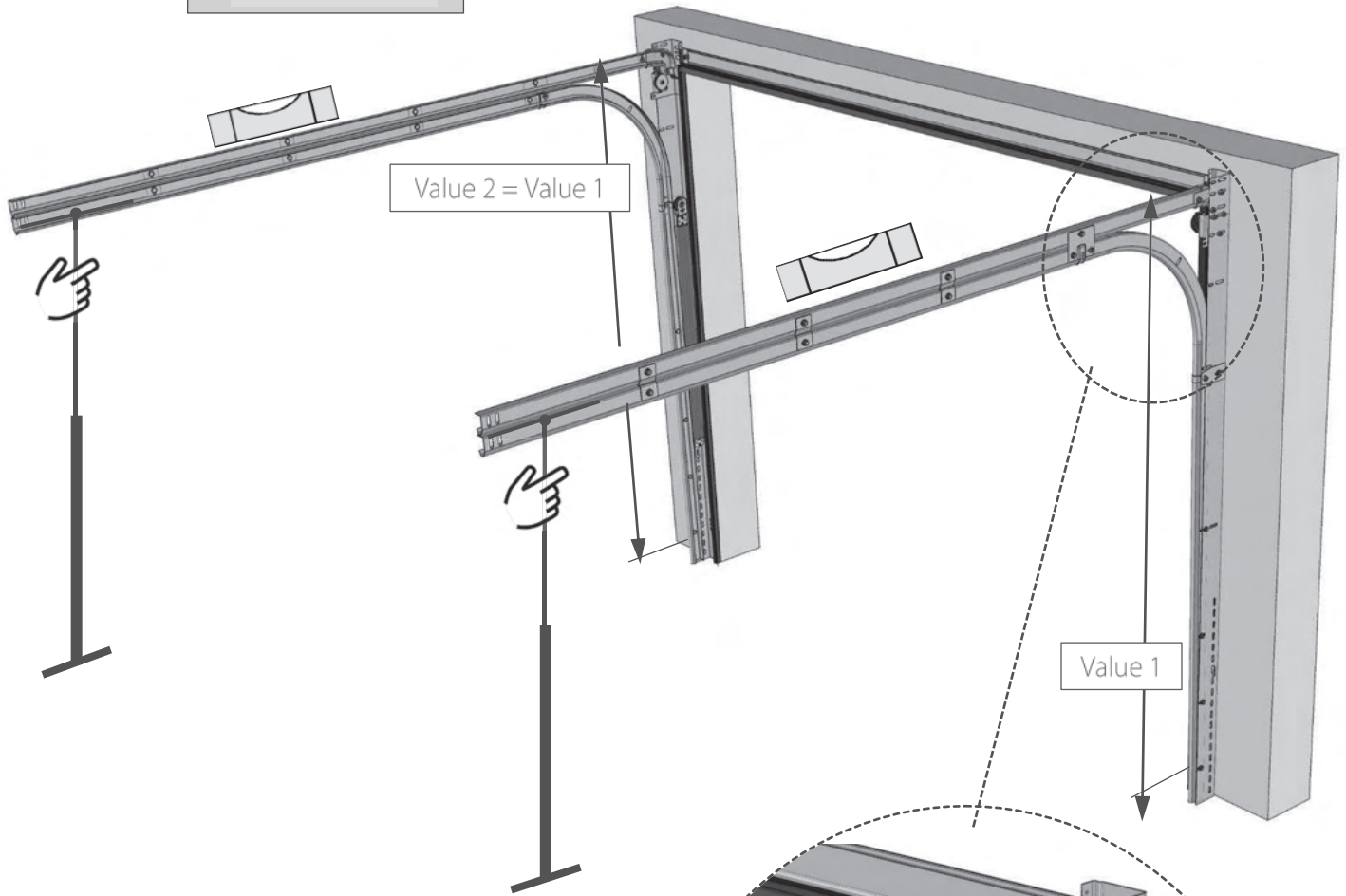

**REINFORCEMENT  
Door > 100 kg**

**Kit 824 & 825**

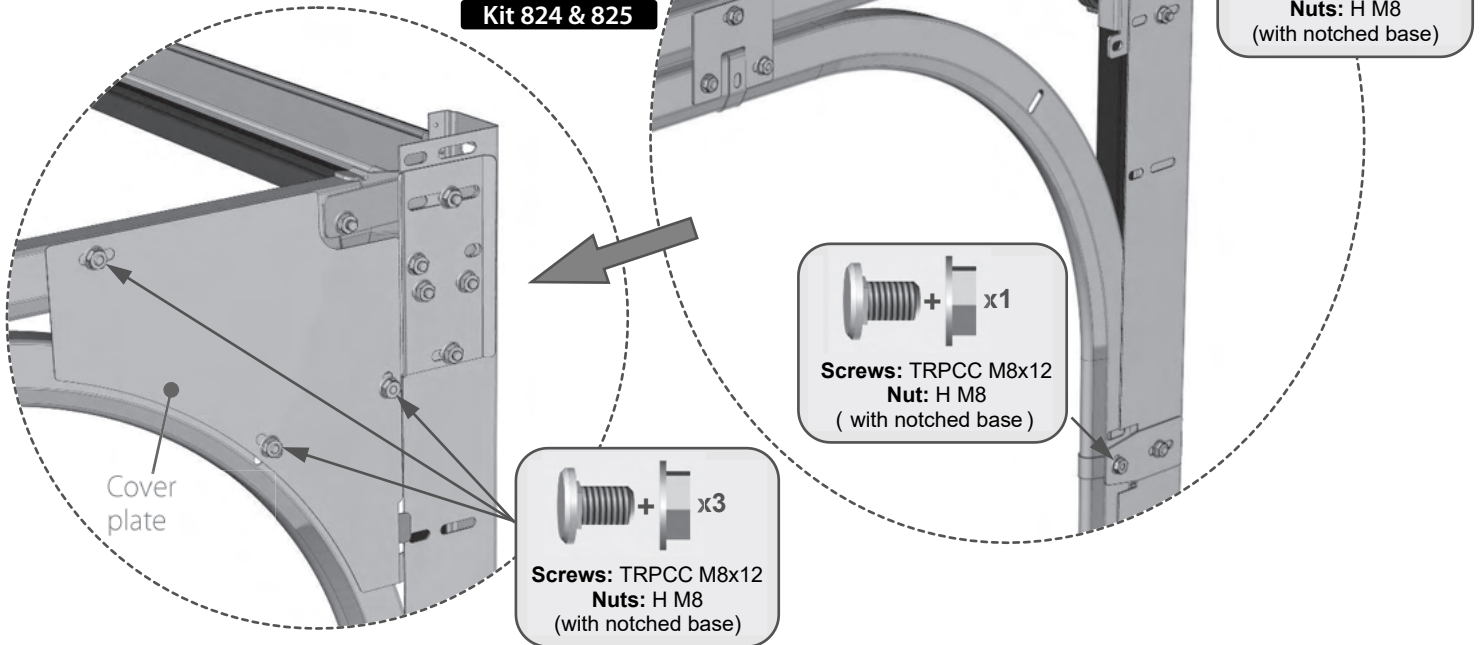

## ASSEMBLING THE BACK BAR BRACKETS

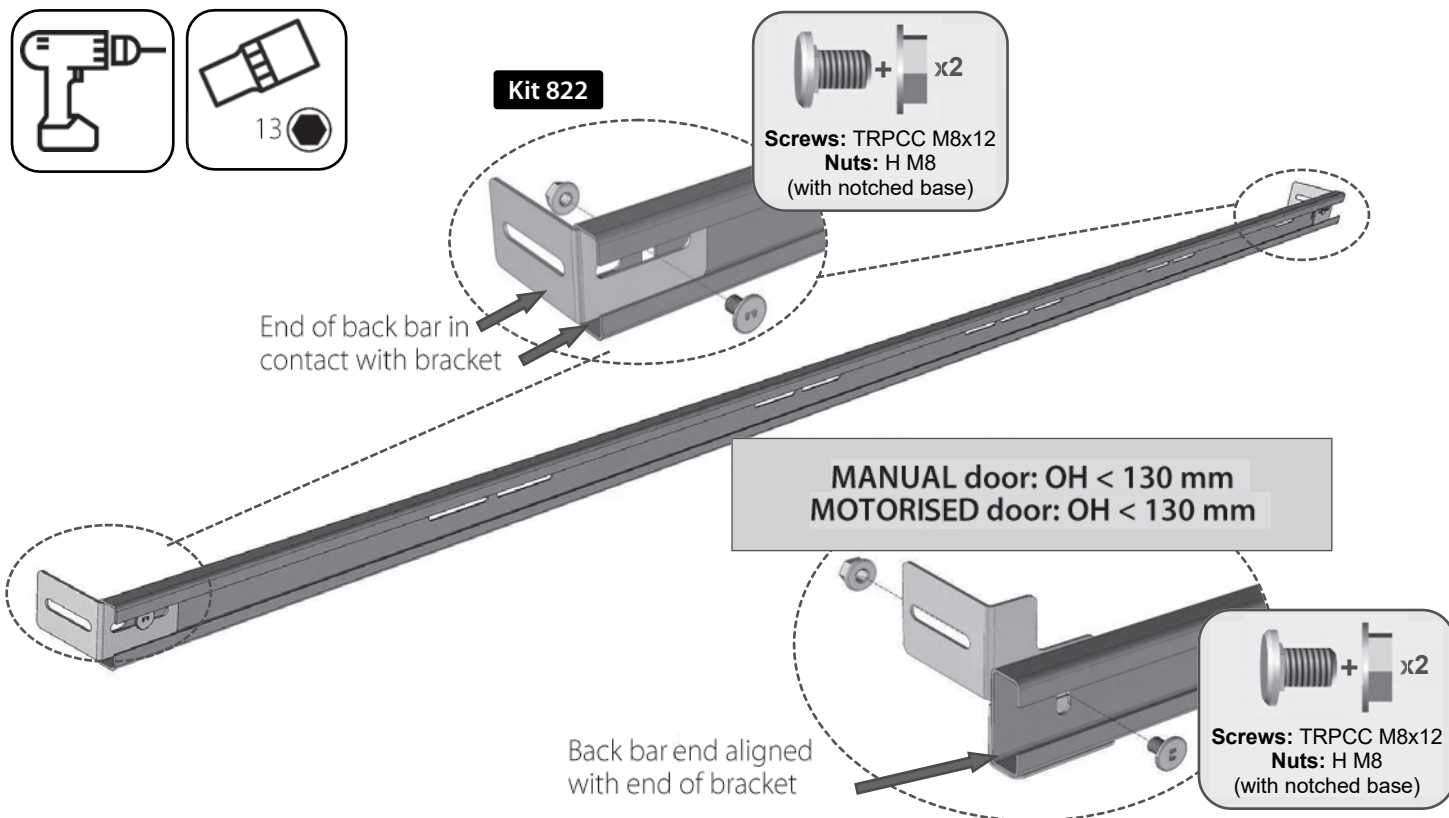

## INSTALLING THE BACK BAR

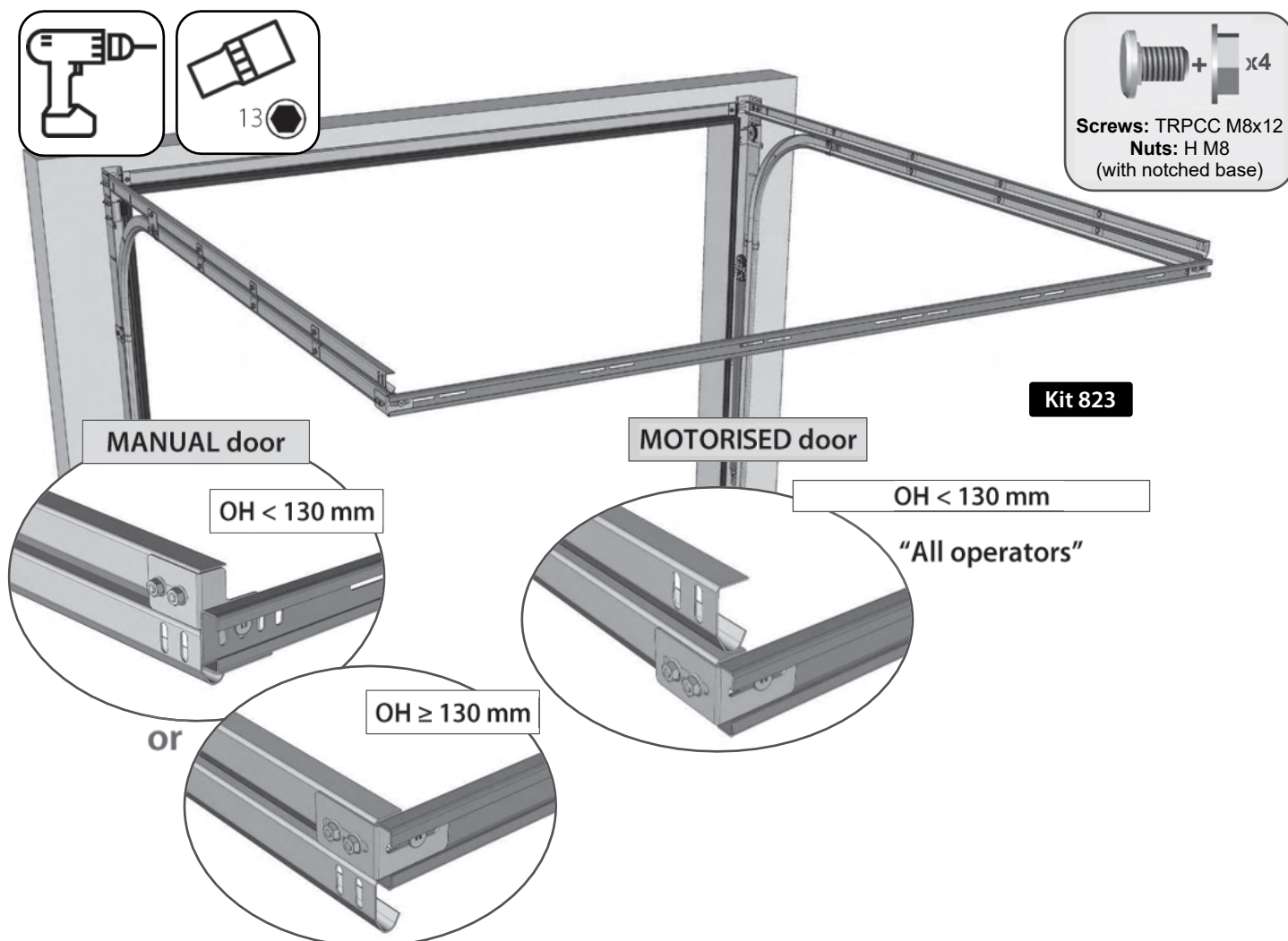

# INSTALLING THE HANGERS

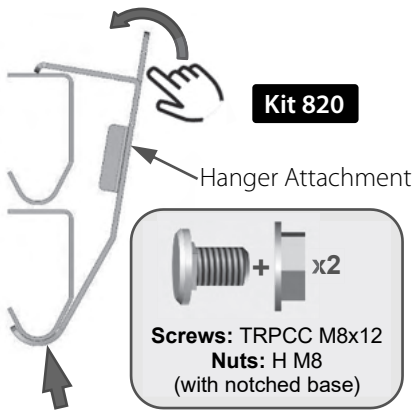

**Kit 820**



Do not fasten the hangers to the masonry.  
Do not fully tighten the screws with nuts.

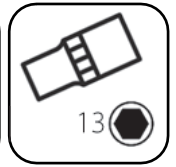
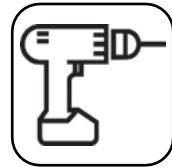

**Adapt the number of hangers to the dimensions of the doors:**

- 2 hangers, if  $PW \leq 3000$  or  $PH \leq 2150$  mm
- 4 hangers, if  $PW > 3000$  or  $PH > 2150$  mm

**Assembly:  $OH < 130$  mm**

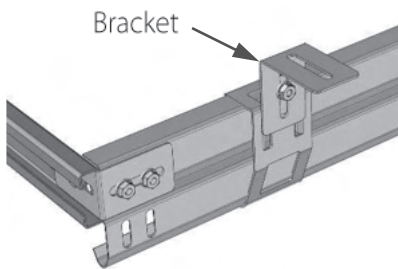

**Assembly:  $130 \text{ mm} \leq OH \leq 440$  mm**

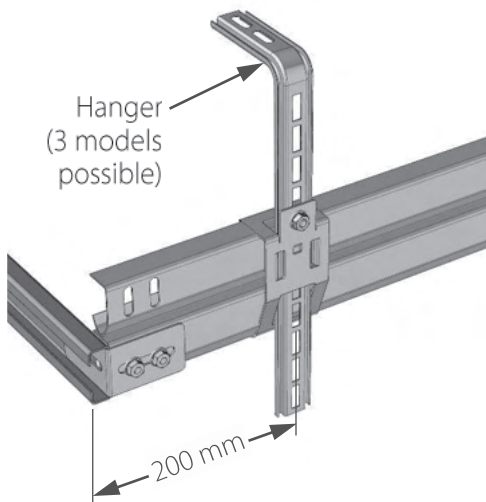

**Assembly:  $OH > 440$  mm**

Adapt the perforated corner on site

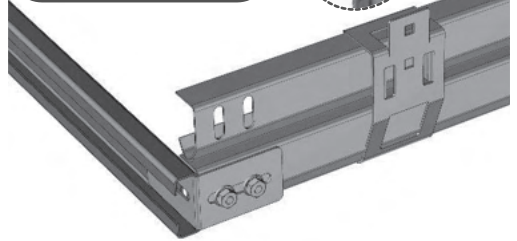
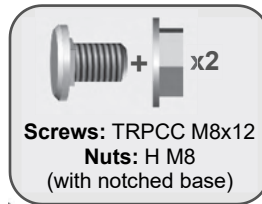

Back bar extension (option)

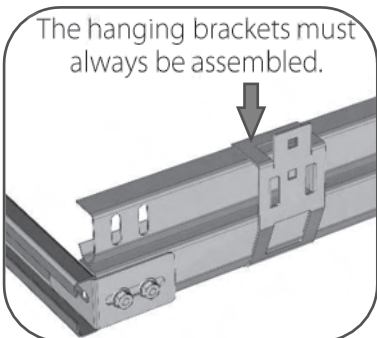

**Headroom  $\leq 300$  mm**

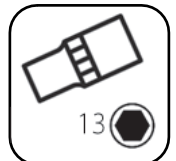
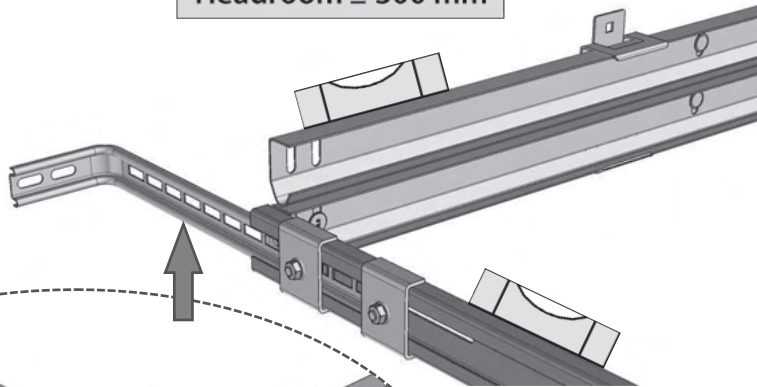

Hanger: 408 mm



Do not fully tighten the nuts.

Clamping-plates

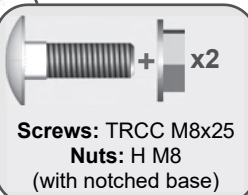

Repeat the process on the opposite side.

**$300 \text{ mm} < \text{Headroom} \leq 1000 \text{ mm}$**

300 mm < Headroom ≤ 1000 mm

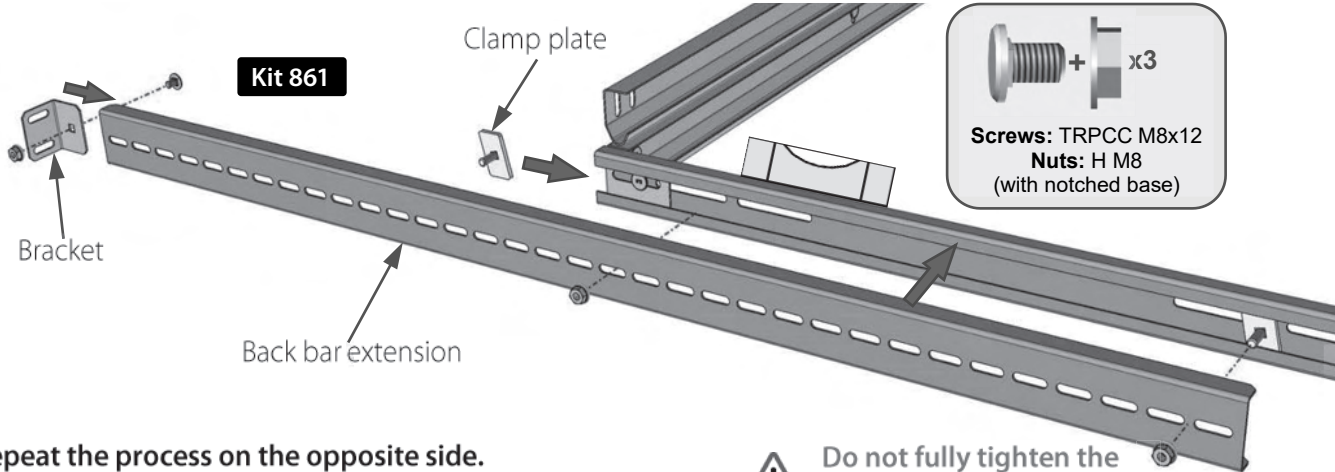

**Kit 861**

Clamp plate

Bracket

Back bar extension

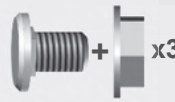
 x3  
**Screws:** TRPCC M8x12  
**Nuts:** H M8  
(with notched base)

Repeat the process on the opposite side.



Do not fully tighten the nuts.

## CHECKING THE DIAGONALS

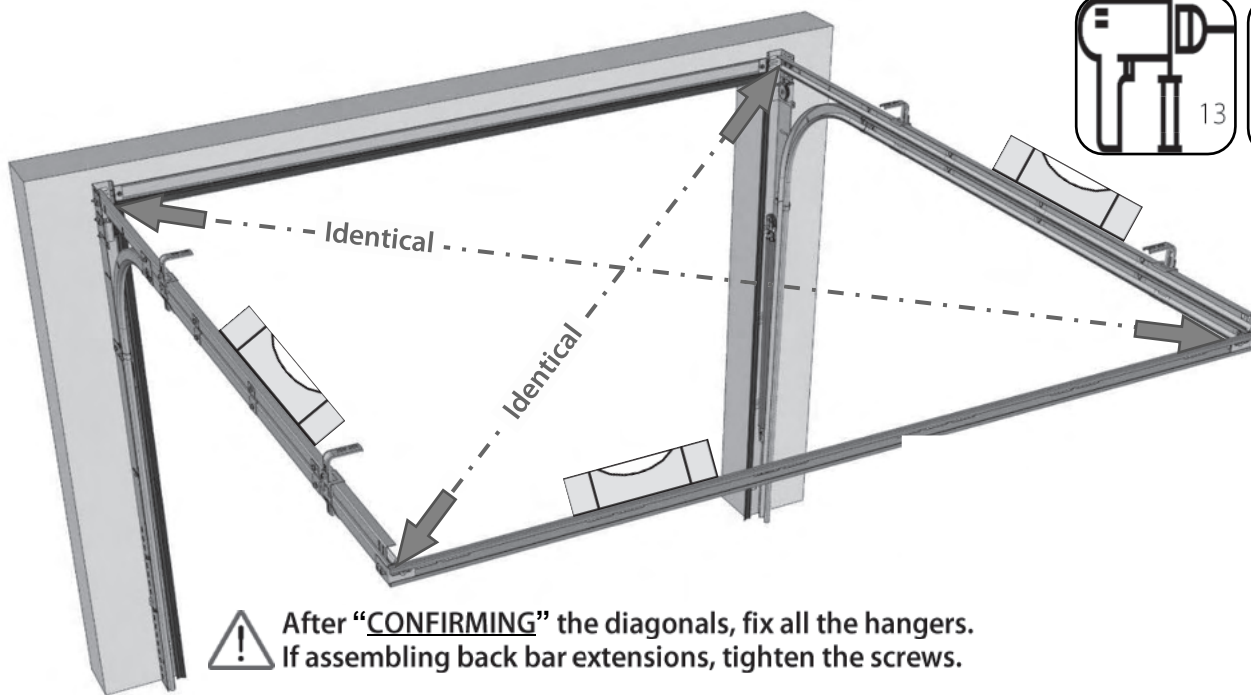

After **“CONFIRMING”** the diagonals, fix all the hangers.  
If assembling back bar extensions, tighten the screws.

# 08. PANEL ASSEMBLY

## IDENTIFYING THE OPENING DIRECTION

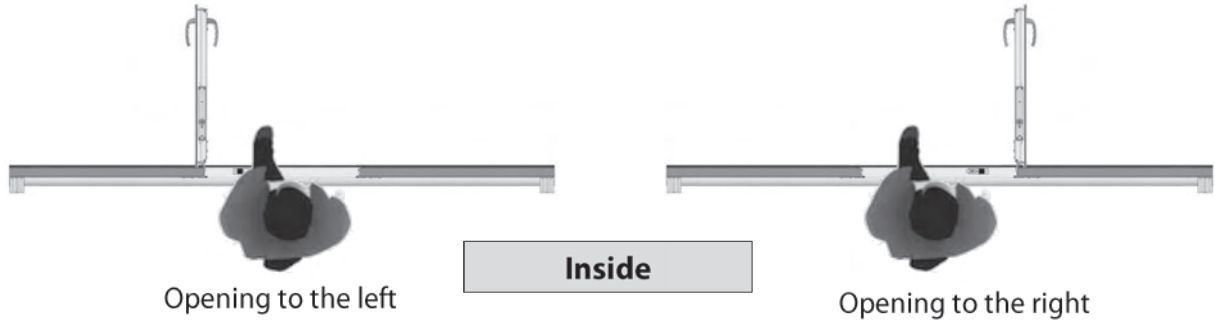

## PANEL PREPARATION

### BOTTOM PANEL

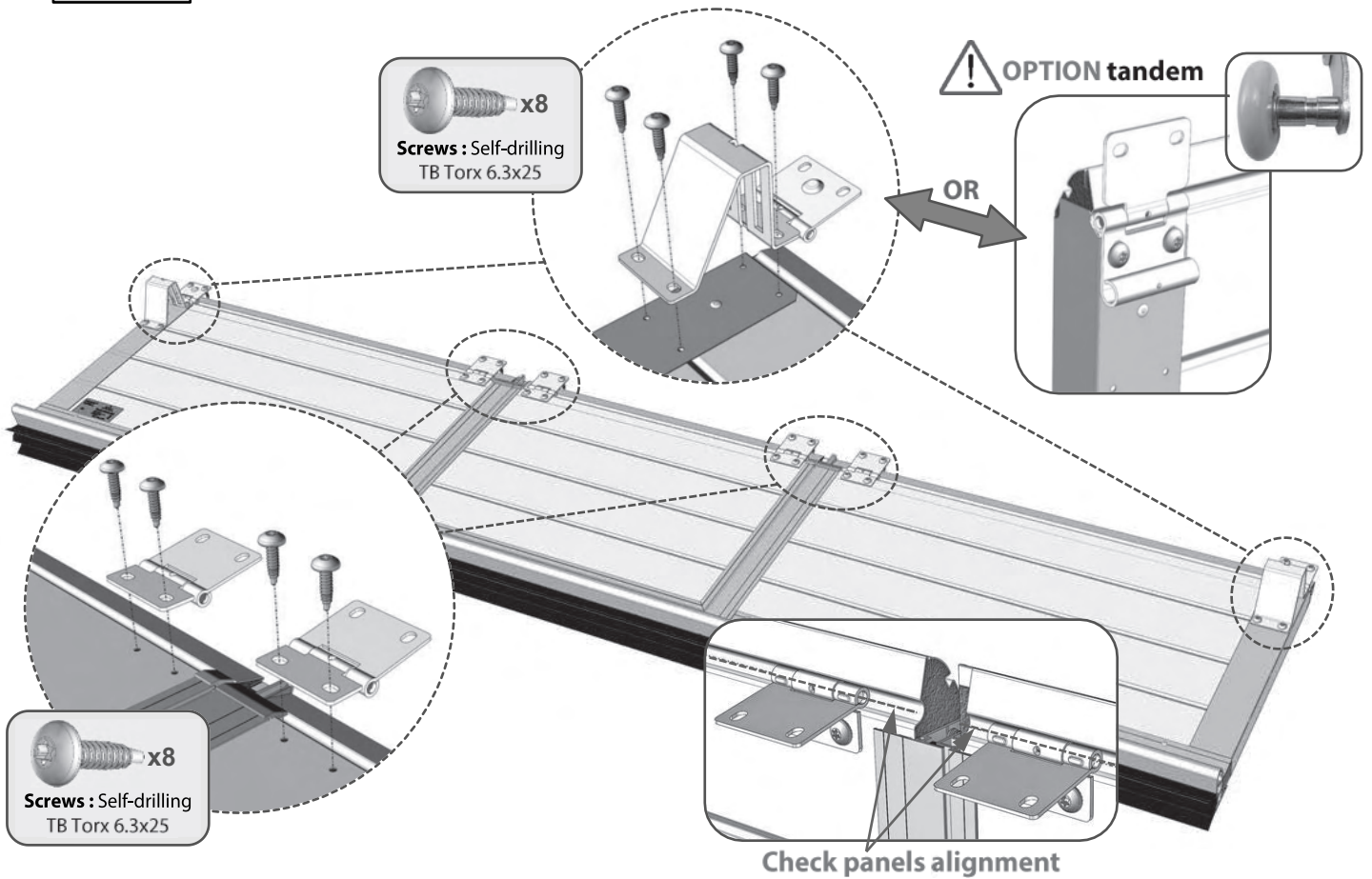
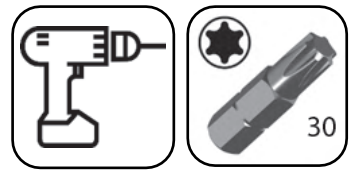
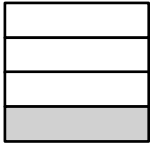

# MIDDLE PANEL(S) ASSEMBLY

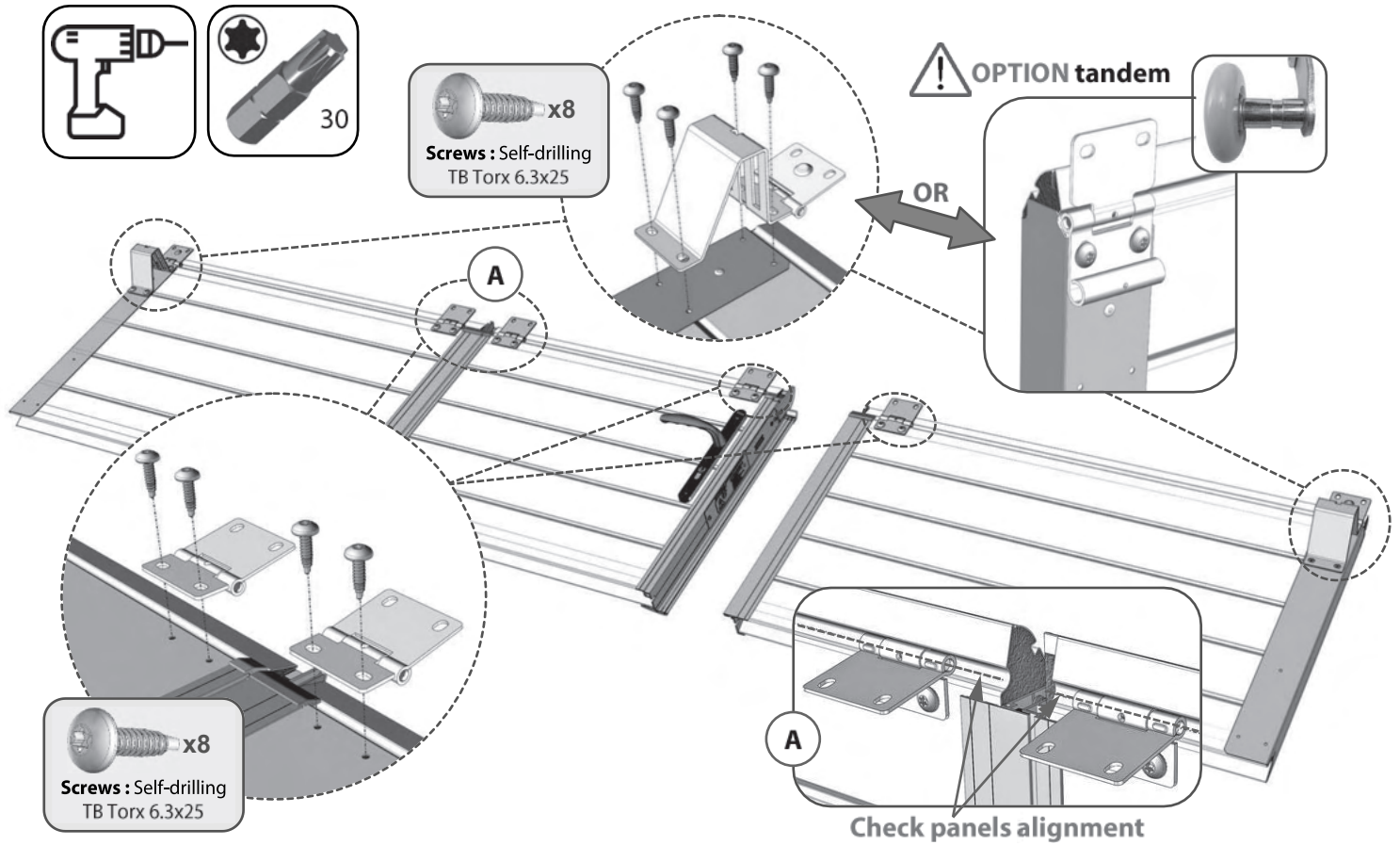

## Assembling the handle and cylinder on intermediate panel no. 1 (recommended) :

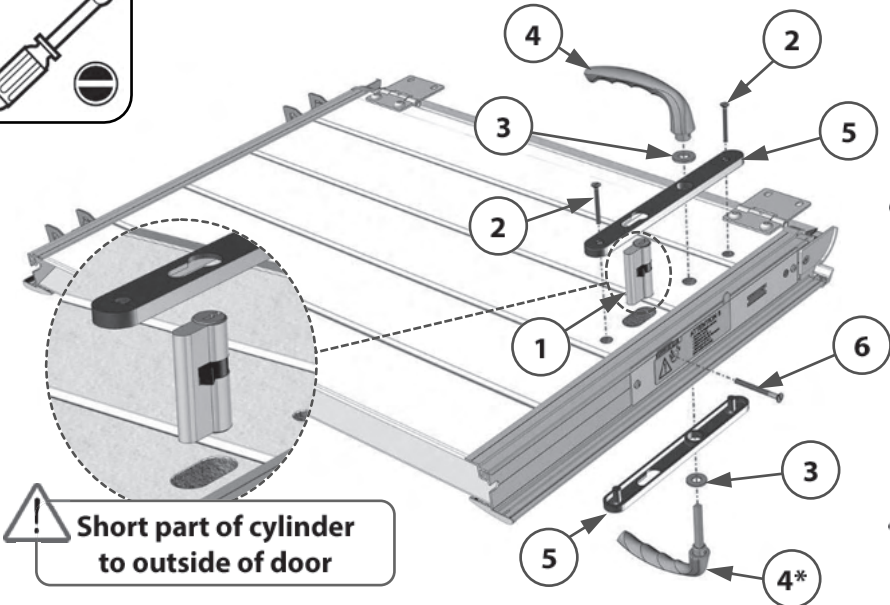

Fix the finger plate screws on the inside of the door.

1. Bushing
2. Flat TF screws M4x50 (x2)
3. Shimming washer (x2)
4. Handle (x2)
5. Finger plate (x2)
6. M5x75 screws (adjust if necessary)



If  $OH \leq 130$  mm, assemble the reduced handle **4\*** on the outside.

## Specific case : Single-grooved panel

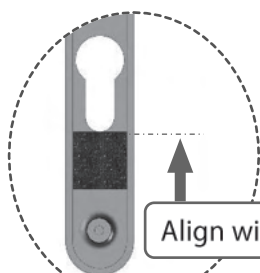

Align with the passage of the cylinder

Stick the block onto the external finger plate

Compress the block



## UNHOOKING THE SPRINGS

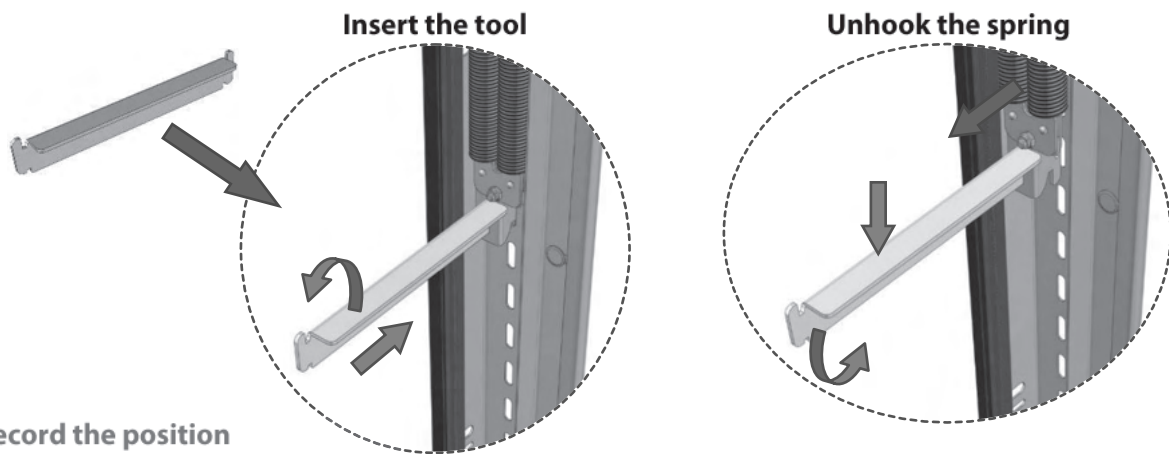

 Record the position of the springs before unhooking.

Repeat the process on the opposite side

## INSTALLING THE BOTTOM PANEL

**Position the panel in front of the rails :**

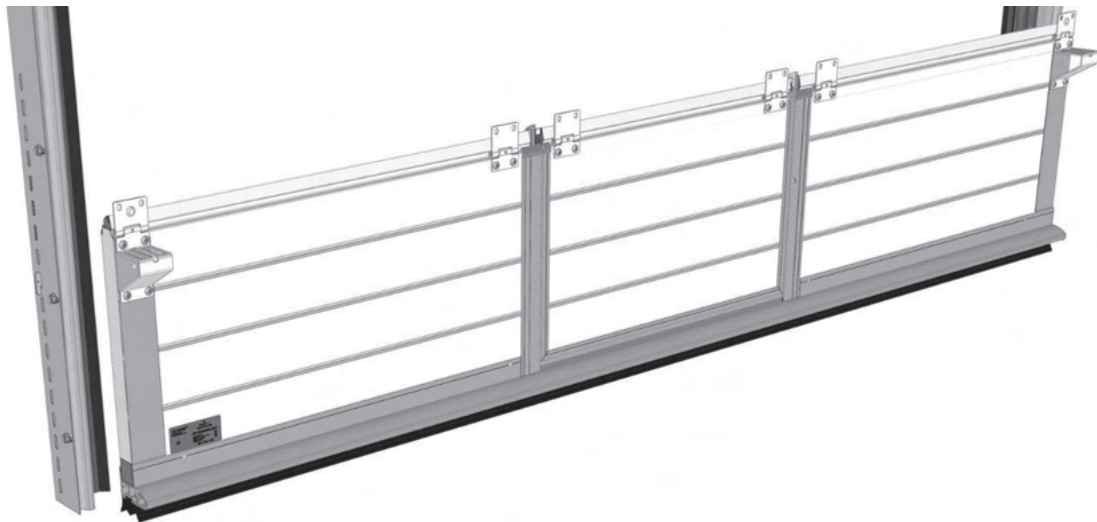

**Cut the LEFT side of the cable-clamp :**

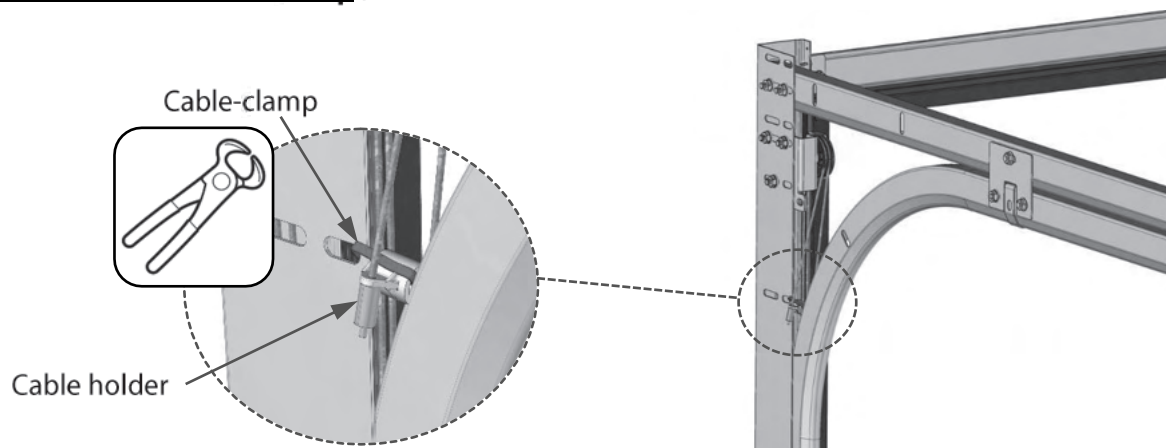

**Insert the "cable holder" and "roller" in the LEFT side of the threshold :**



**If reduced 30 mm threshold  
= Low suspension**

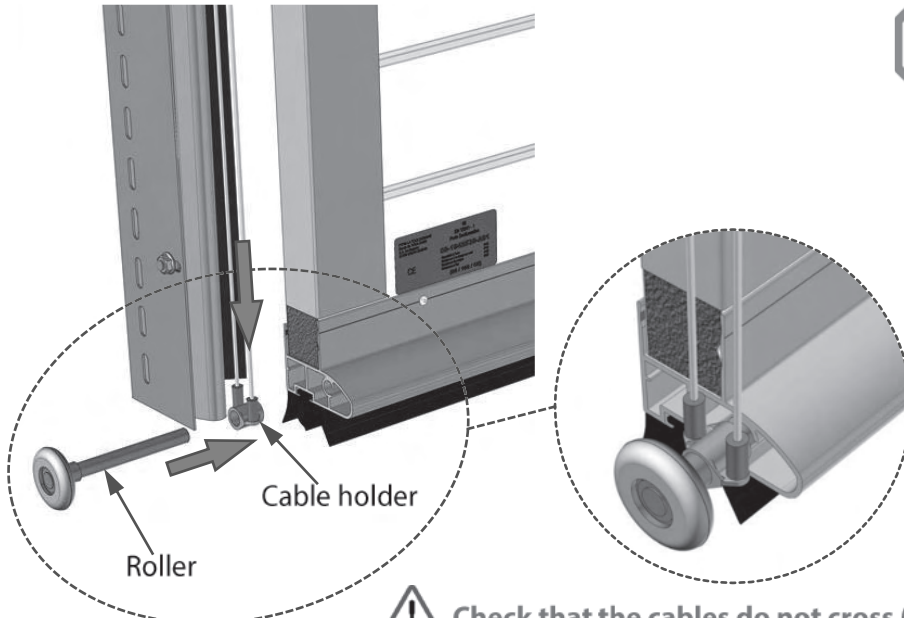
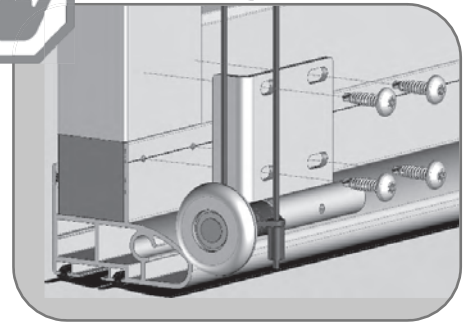

**Check that the cables do not cross (parallel cables).**

**Insert the "roller/cable holder assembly" in the LEFT vertical rail :**

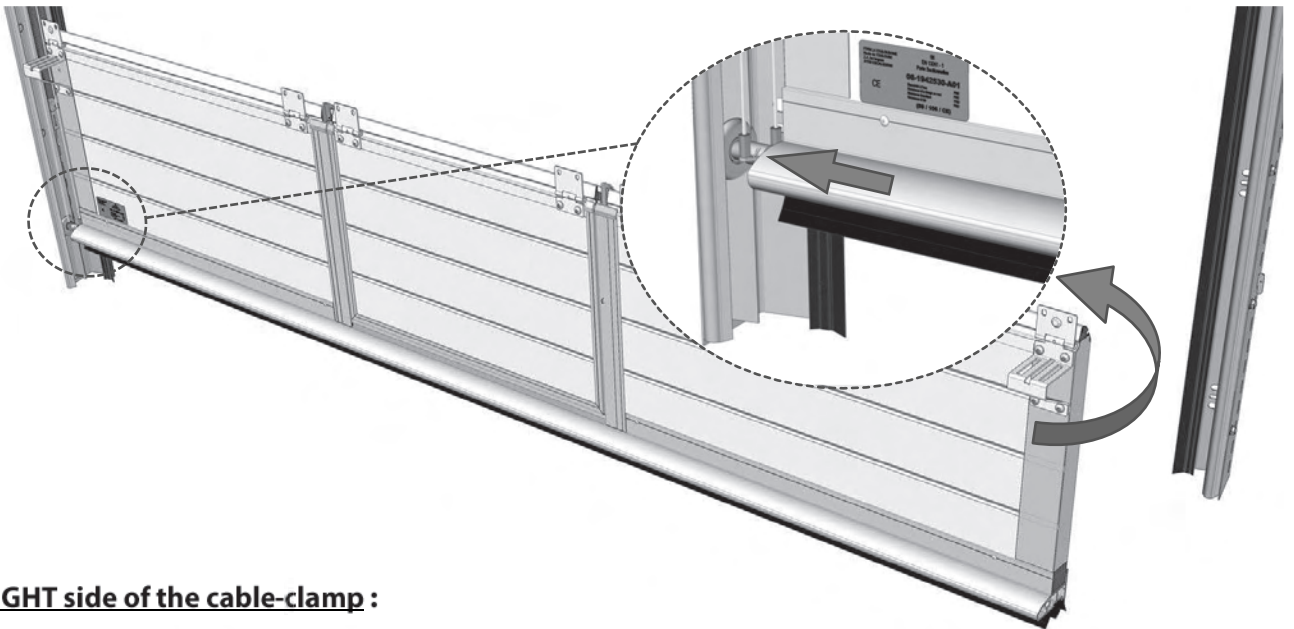

**Cut the RIGHT side of the cable-clamp :**

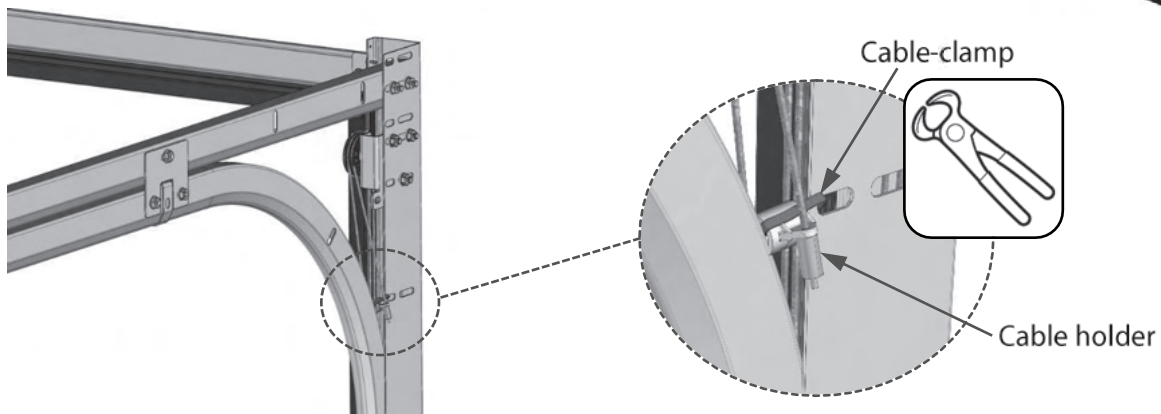



**Insert the "roller" and "cable holder" in the RIGHT vertical rail :**

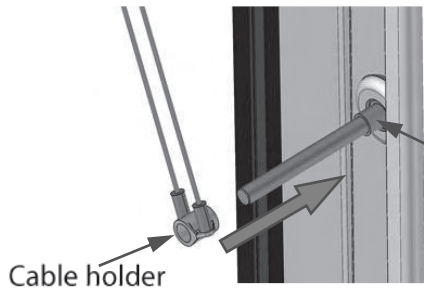

Check that the cables do not cross (parallel cables).



If reduced 30 mm threshold  
= Low suspension

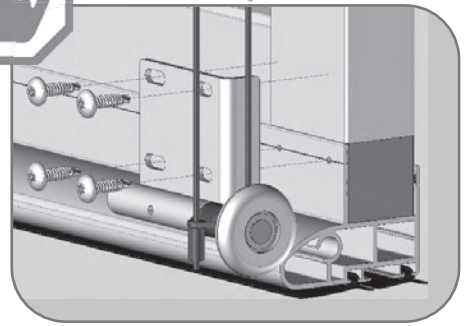

**Insert the "roller/cable holder assembly" in the threshold :**

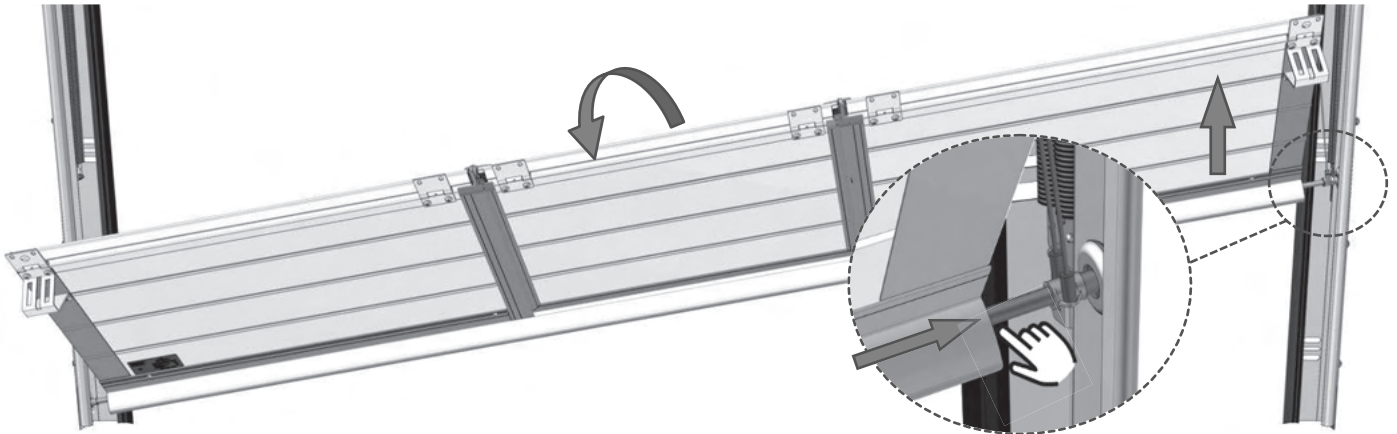

## Insert shims and finalise the guides

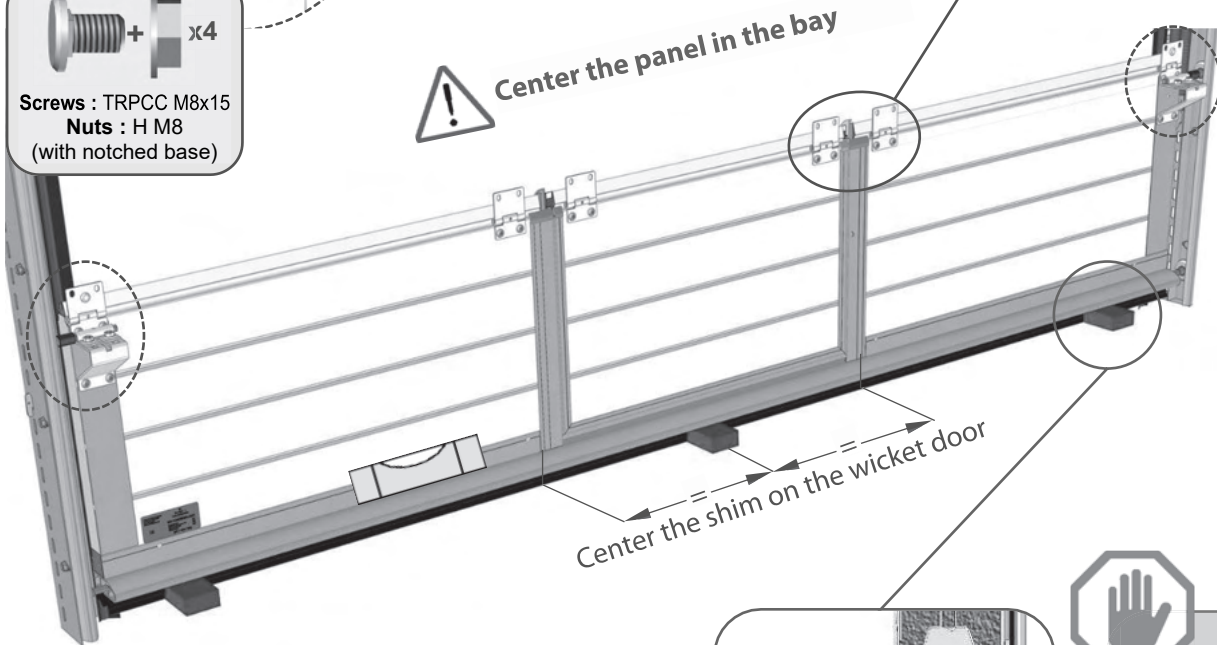
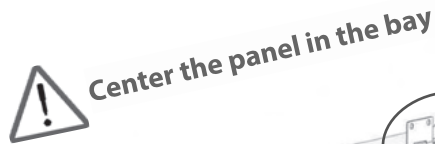
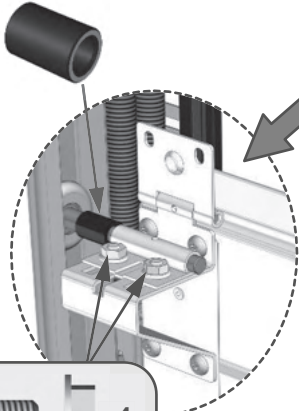
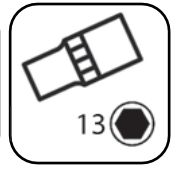
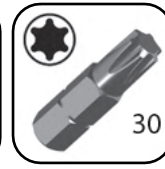
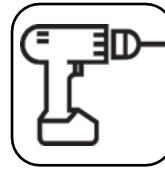
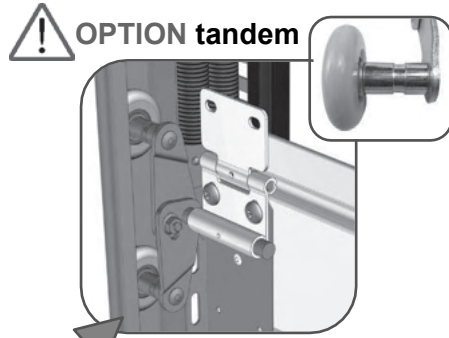

Center the shim on the wicket door

**To install the bottom panel at the correct level, place shims (not supplied) high enough under the threshold to avoid flattening the bottom seal when assembling the panels.**

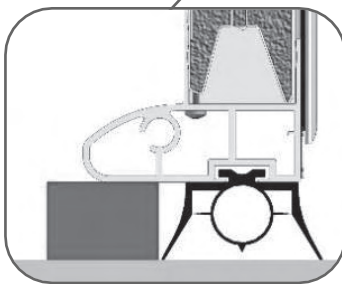

Standard 60 mm threshold  
= Shim height 40 mm

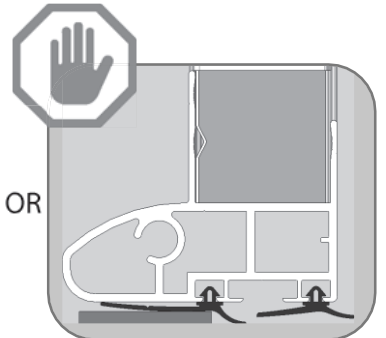

If reduced 30 mm threshold  
= Shim height 10 mm

**Please note :** If the wicket door is off center, add 1 shim under the longest side.



**Insert shims and check the wicket door :**

1- Prepare the control jig :

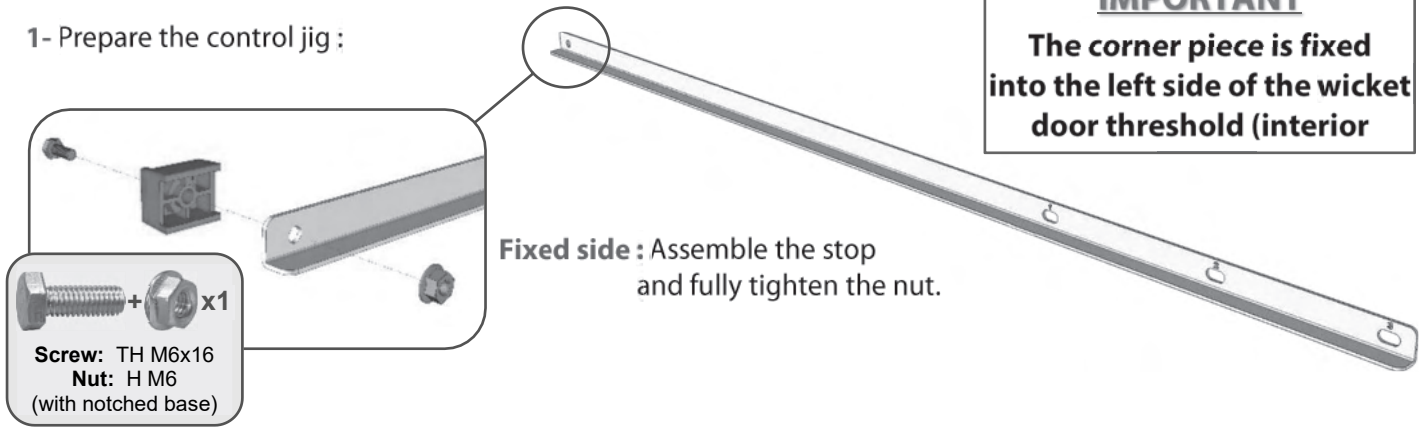

**IMPORTANT**  
The corner piece is fixed into the left side of the wicket door threshold (interior)

2- Position the jig on the threshold of the wicket door :



**Mobile side :**

Position the stop on the corner piece according to the wicket door width ; assemble it and fully tighten the nut.

Wicket door width	Position of the stop
L (659 mm)	1
XL (789 mm)	2
XXL (900 mm)	3

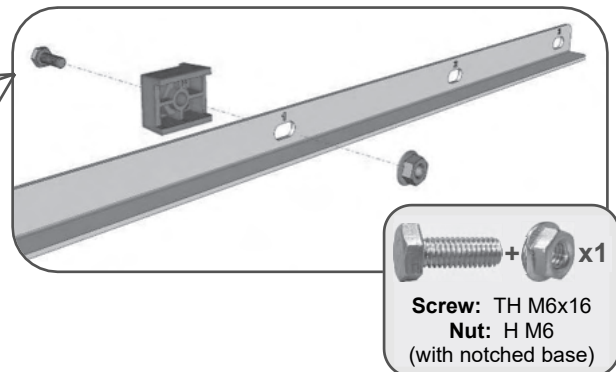

**Please note :** The stops must but up against the frame :

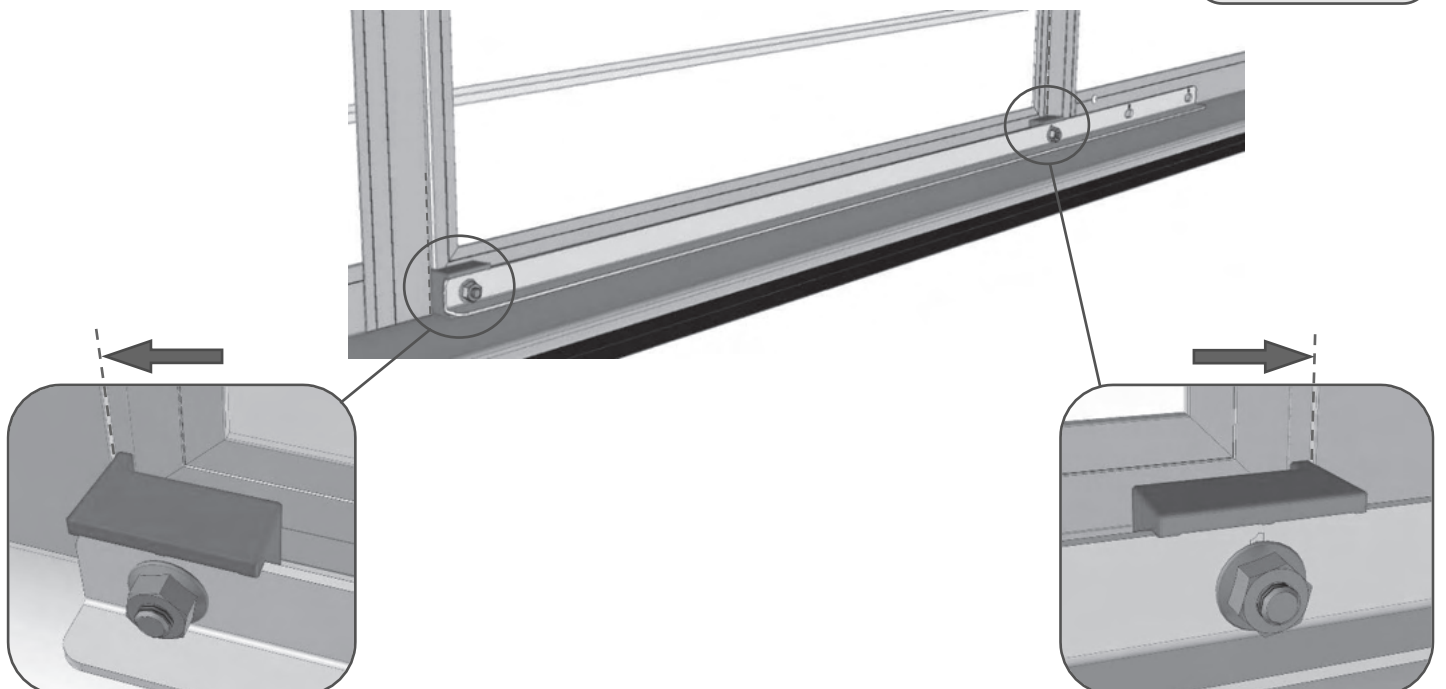

3- Use the jig to check the distance between the frames :

 Check top and bottom

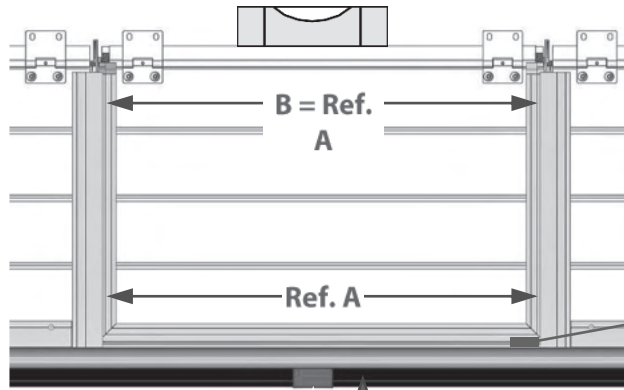
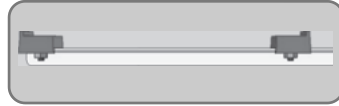

8 mm shim,  
present on lock side

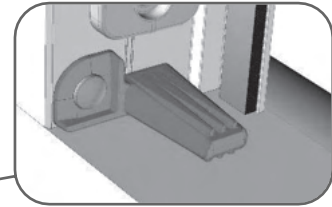

Do not remove

 For B = Reference A, adjust the thickness of the shim.

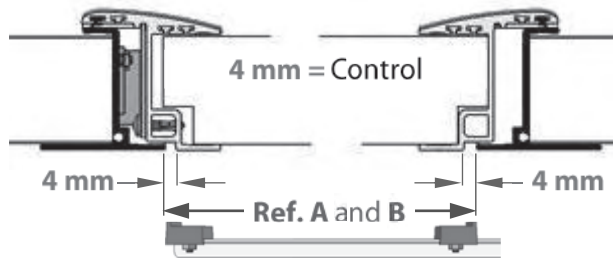

# INSTALLING THE MIDDLE PANEL(S)

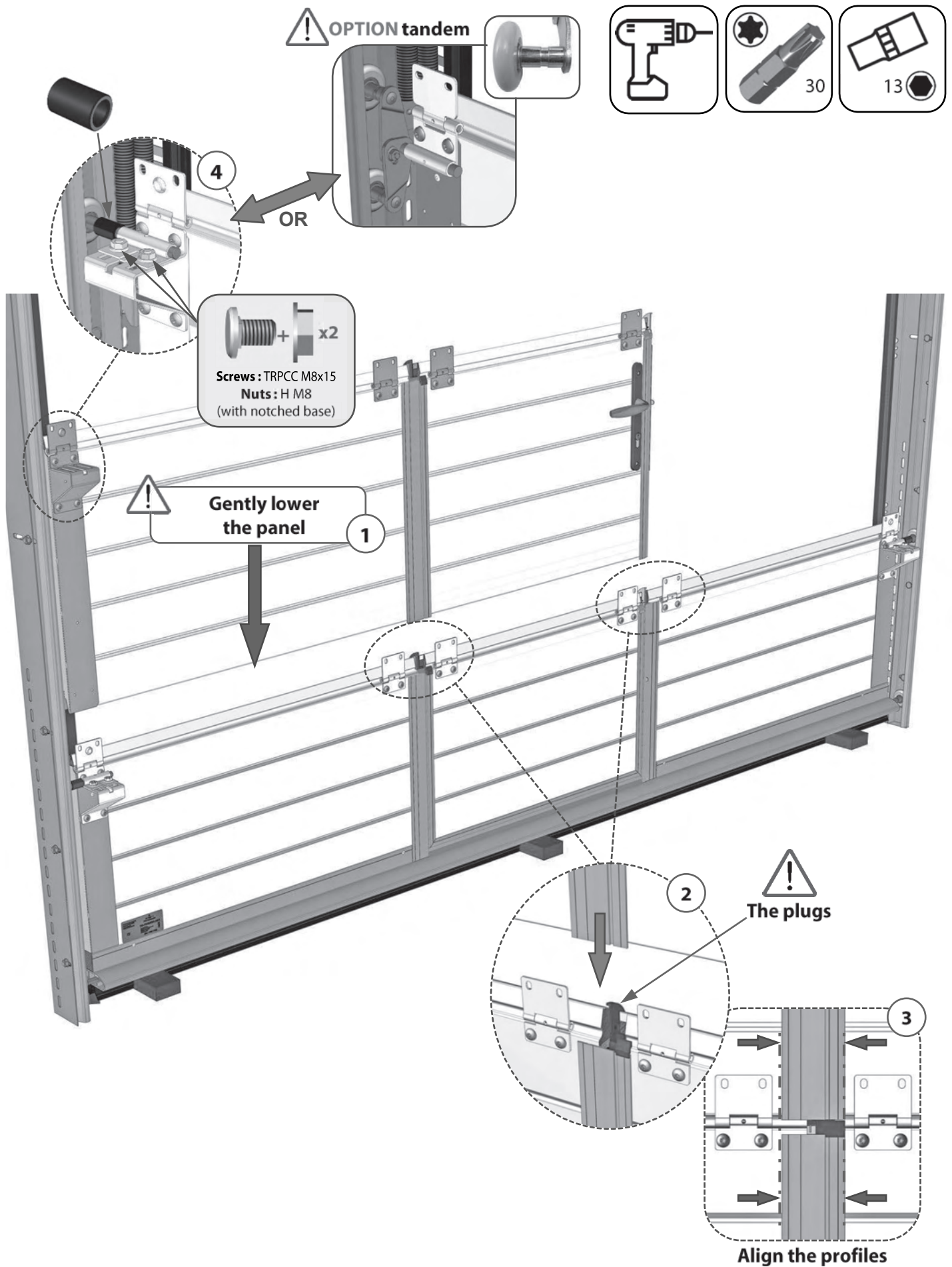

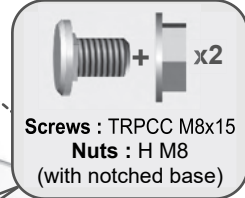
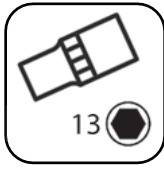

Screws : TRPCC M8x15  
Nuts : H M8  
(with notched base)

! OPTION tandem

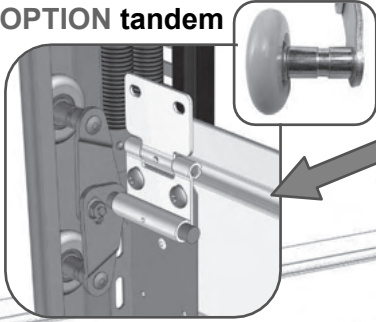

OR

6

9



5

! If the wicket door is off center (250 mm), press firmly on the panel

5

Check they are parallel

(panels resting on hinge knuckles)

9

Ref. A

Align the profiles

7

11



Screws : Self-drilling  
TB Torx 6.3x25

If 8 and 9 are OK

10

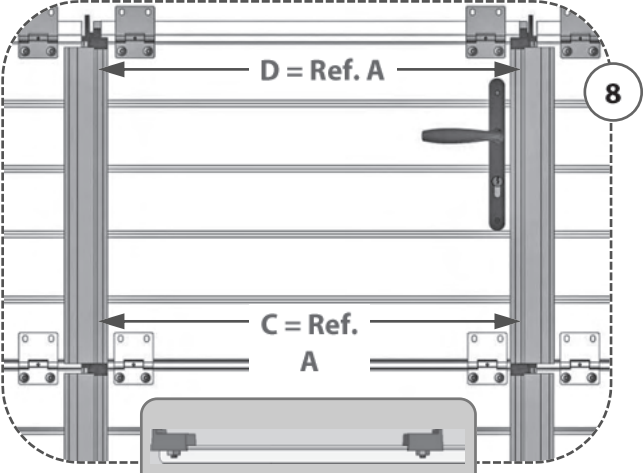
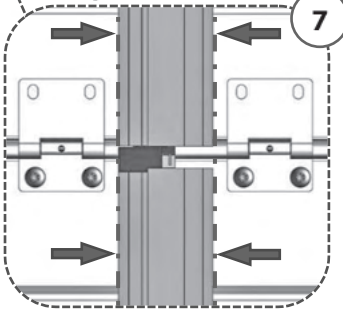

8



Check top and bottom profile

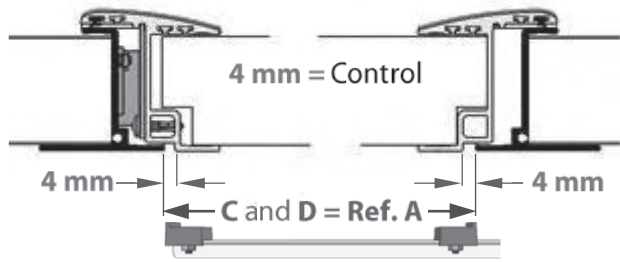

NOTE: If installing a second middle panel, repeat this step for the second panel.

# INSTALLING THE TOP PANEL



If the wicket door opener is less than 50 mm from the header, the door closure before assembling the wicket door top panel. Refer to the **WICKET DOOR FINALIZATION | Door closure**

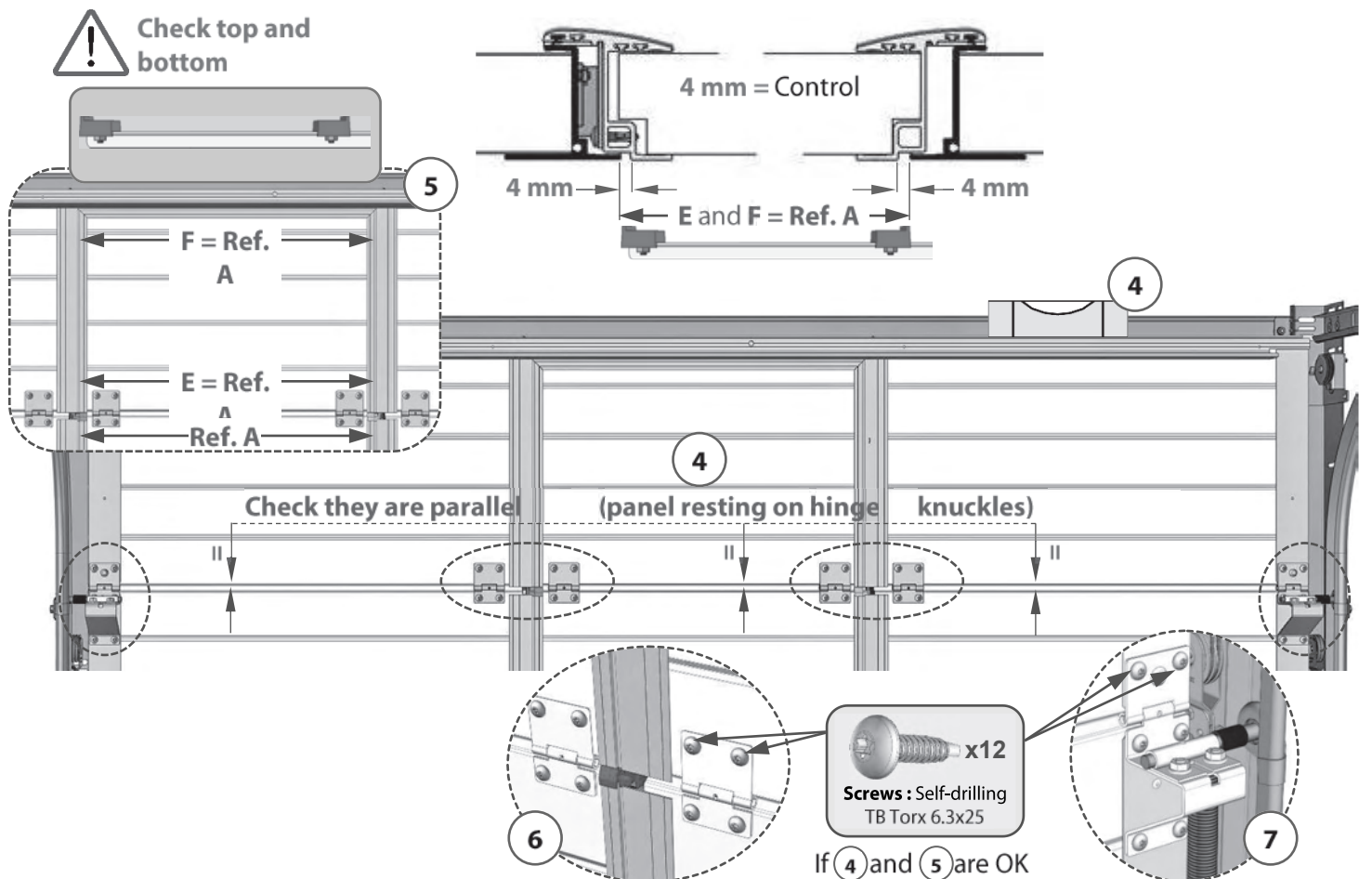
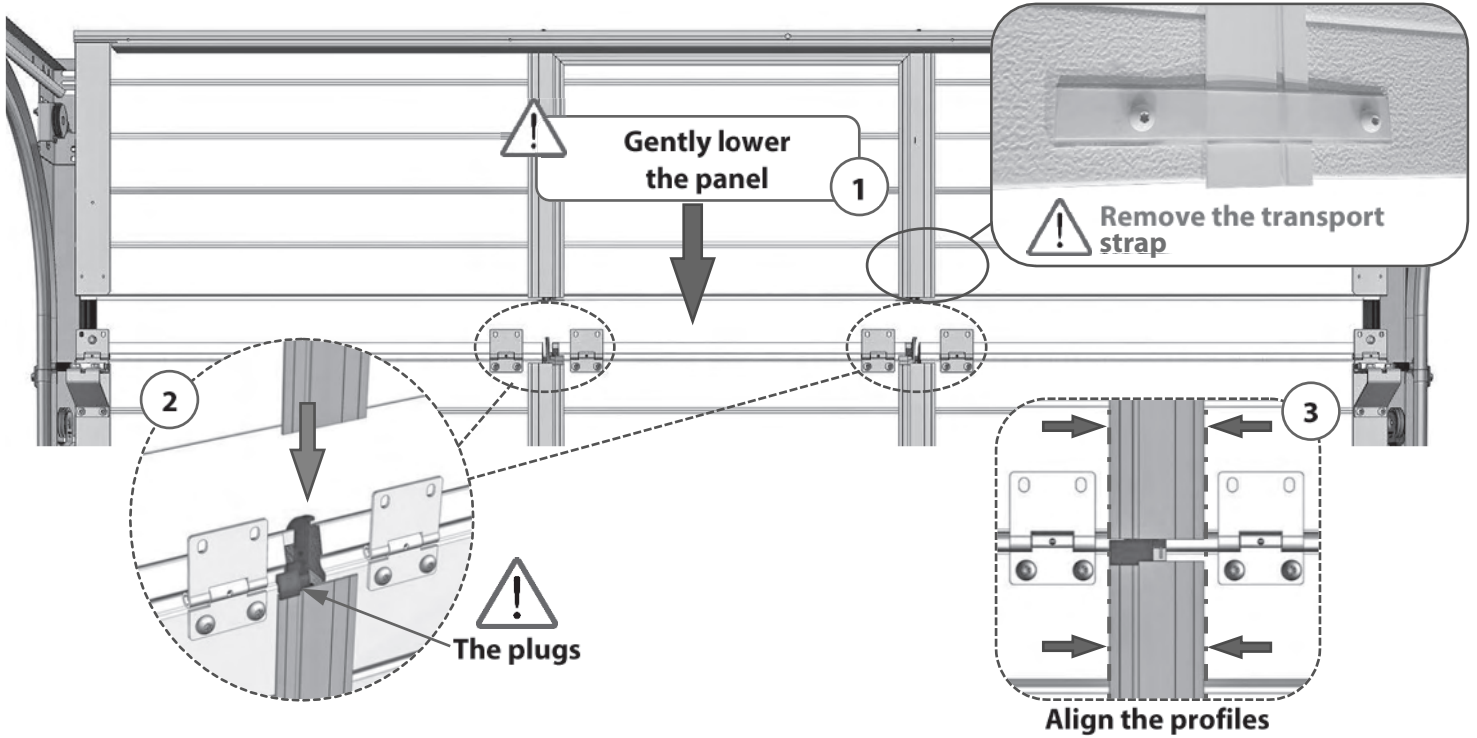

**IMPORTANT** : Remove the transport rivet from the edged column, so that the top roller support rests on a flat surface (identical process on opposite side).

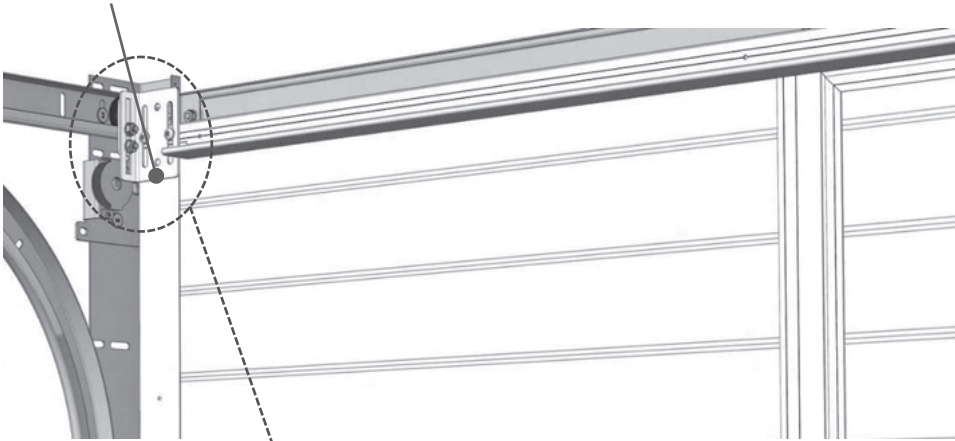

**Assemble the adjustable rollers**

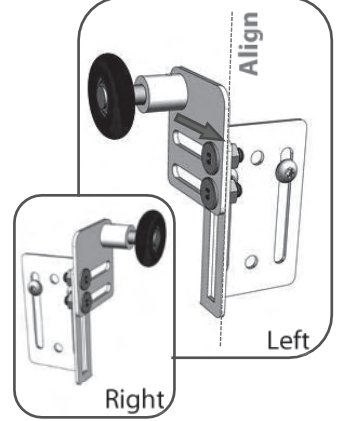

**MOTORISED door**

**MANUAL door**



OR

**Repeat the process on the opposite side.**



# 09. WICKET DOOR ASSEMBLY

## ADJUSTING THE STOP MODULE

Switch on the blocker

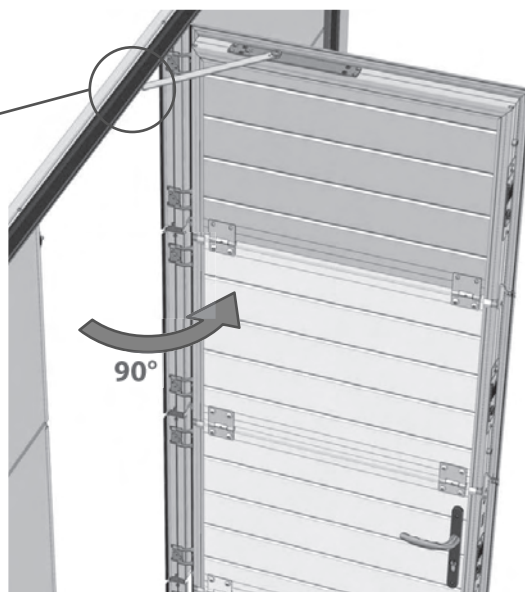
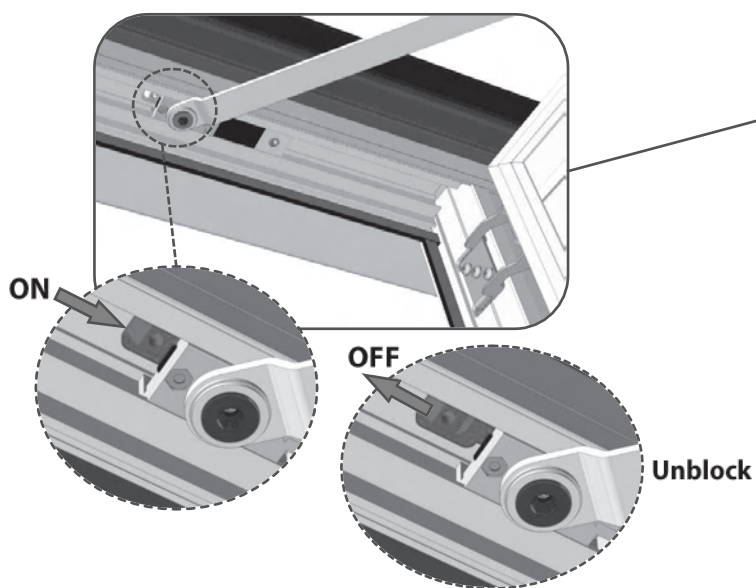

**Test the stop module :** Block the wicket door.

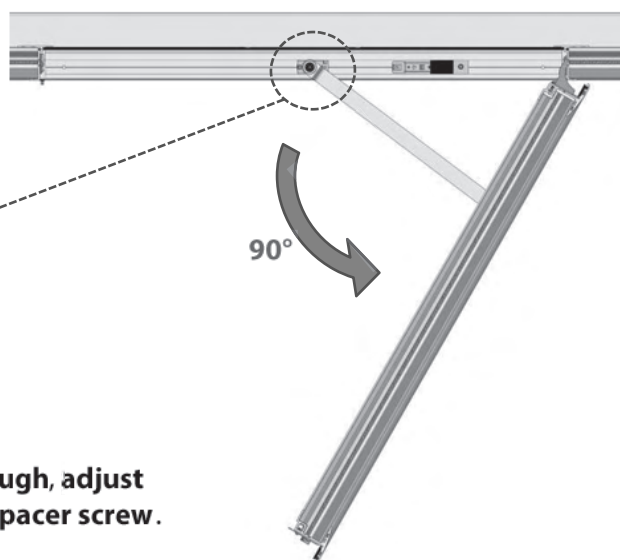
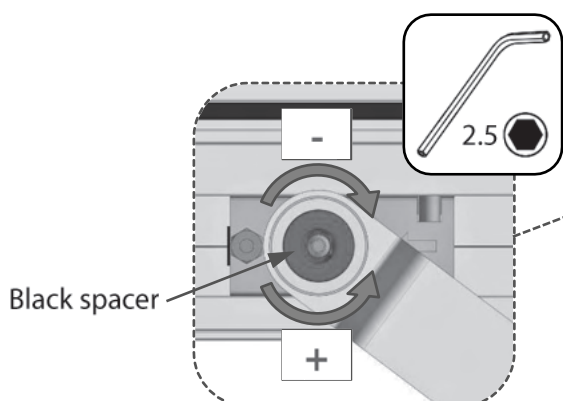

**Please note :** If the stop module blocks too much or not enough, adjust the pressure screw on the inside of the black spacer screw.

remove the shim

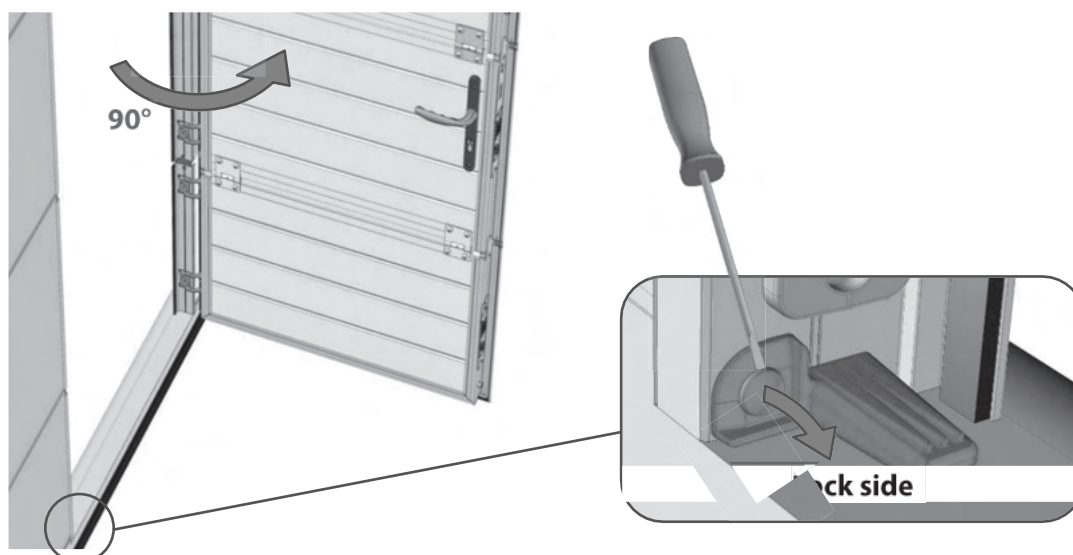

# INSTALLING THE DOOR CABLE

## Add the screws :

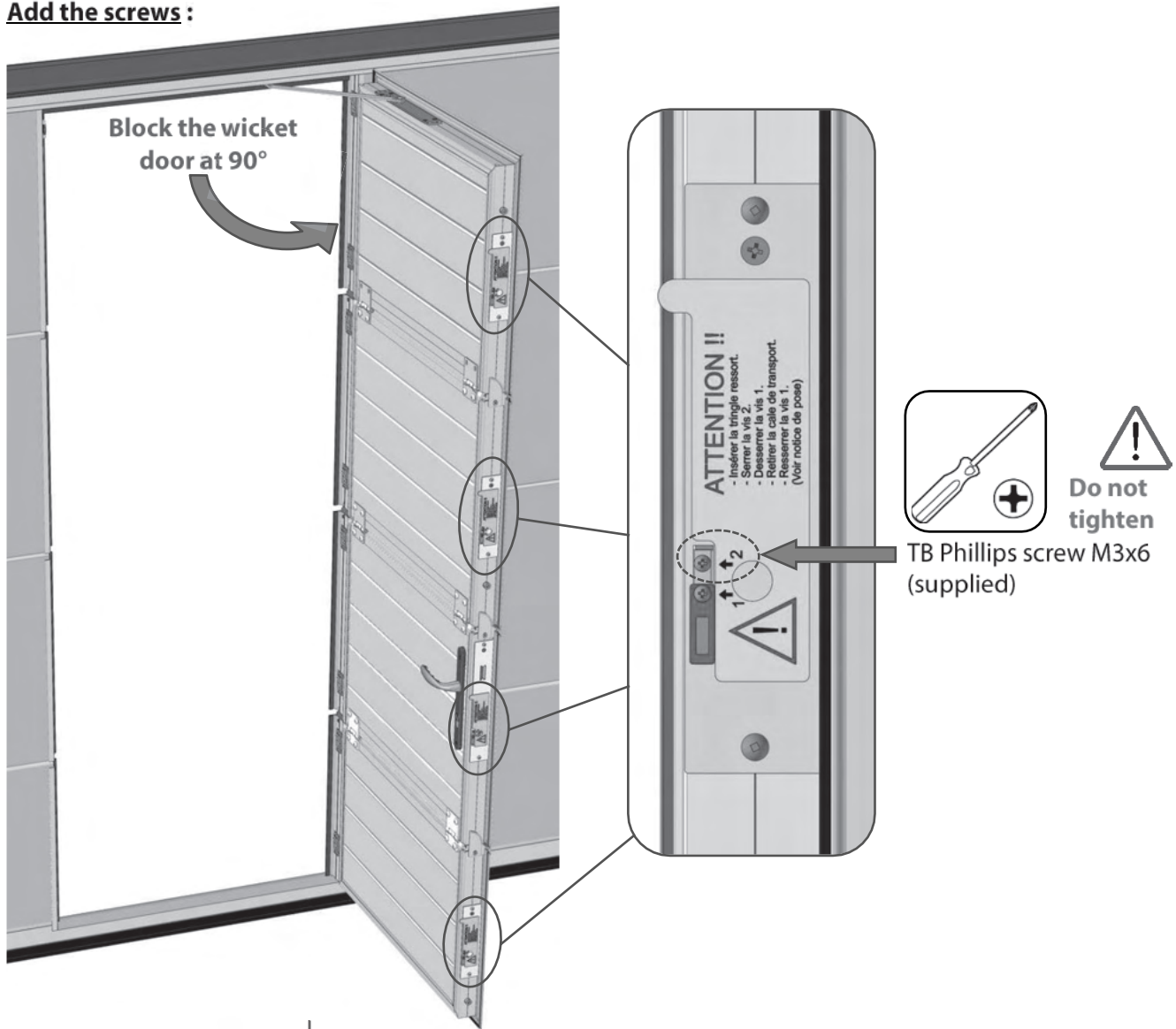

## Mark out the rod :

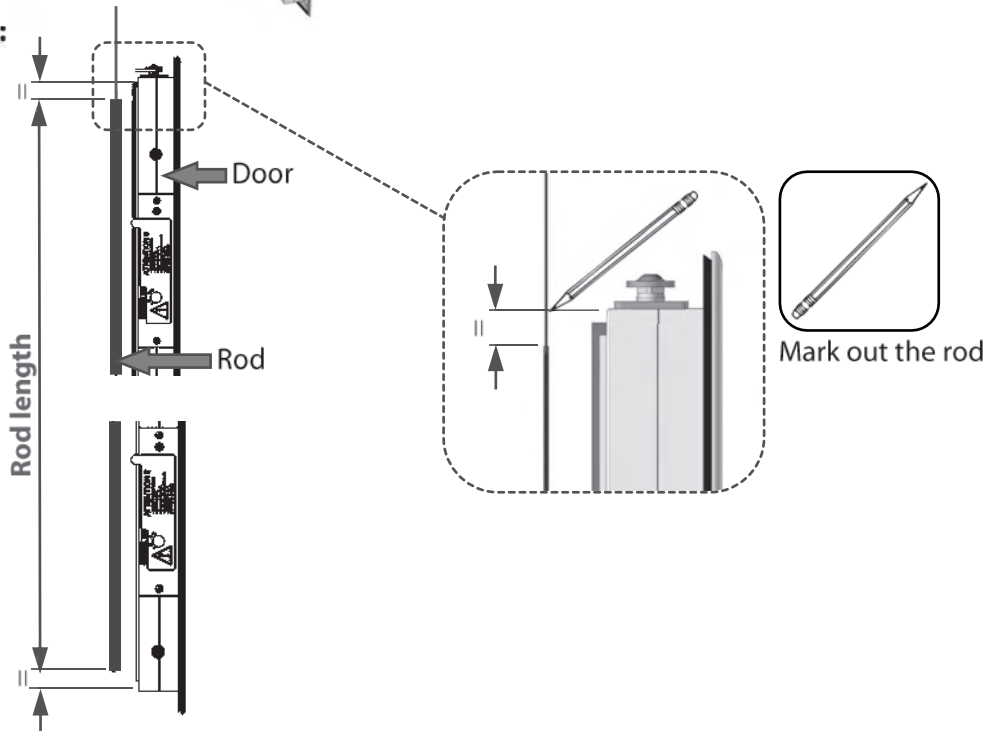

**Insert the rod :**

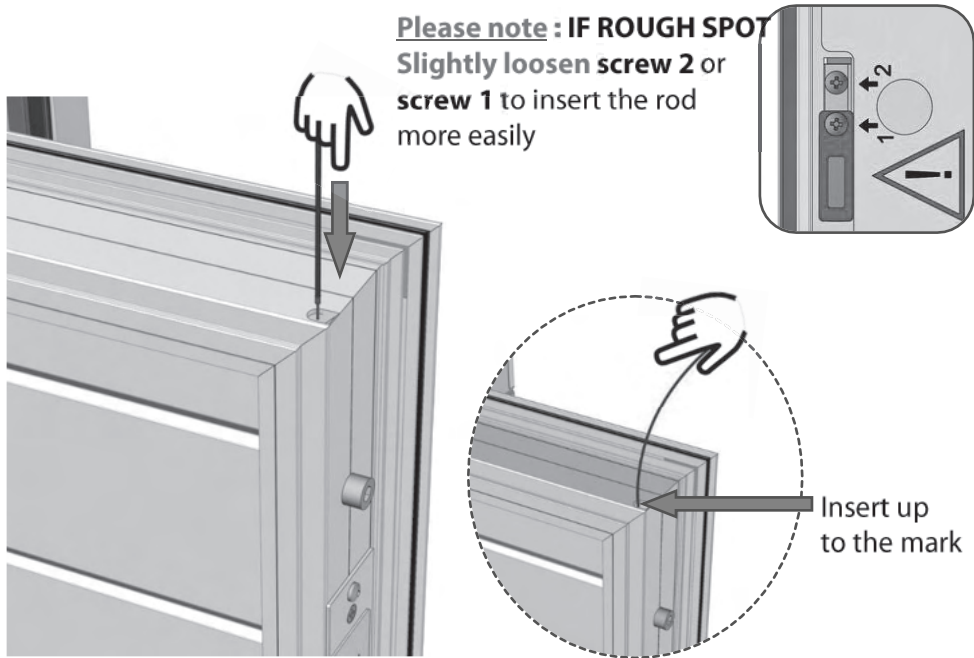

**Tighten the screws :**

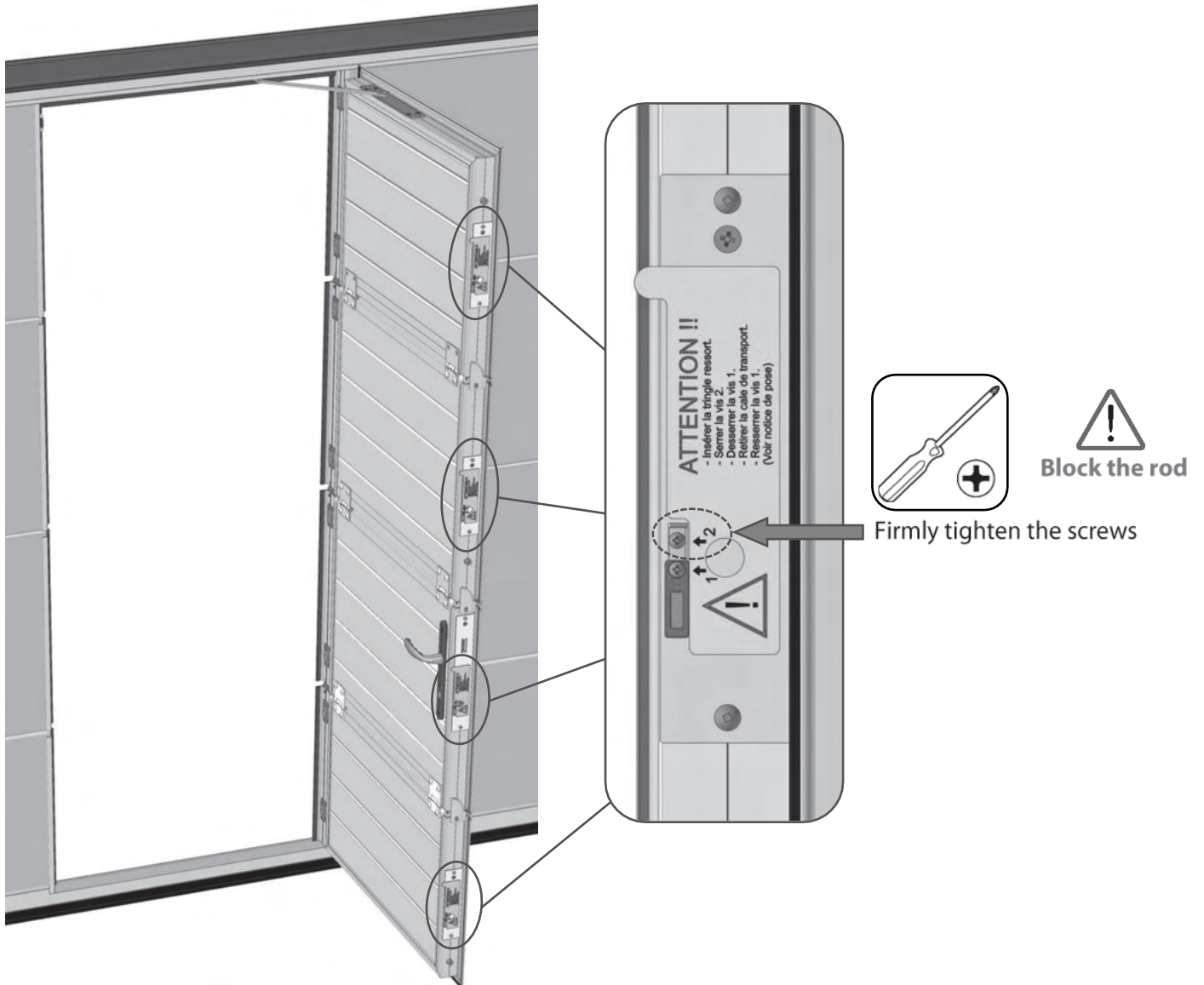



Reinsert the cable

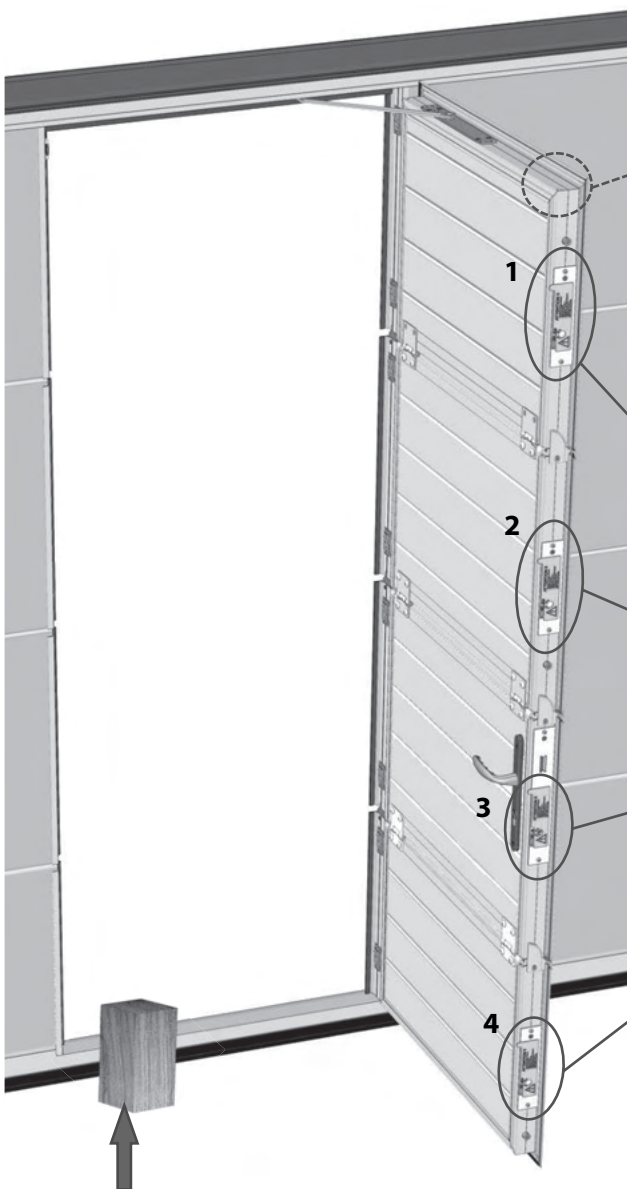
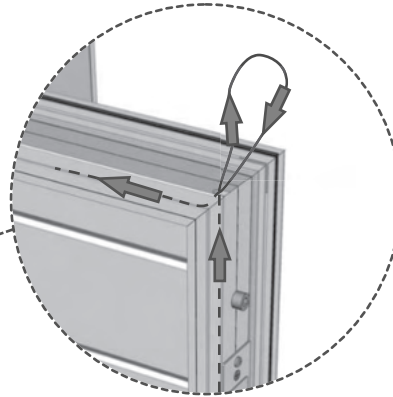

**IMPORTANT** : For points 1, 2, 3 and 4, carry out steps A and B for each shim.

A - Remove the locking shim

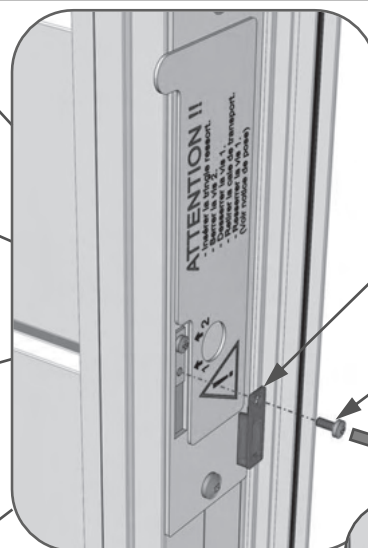

Locking shim

TB Phillips screw M3x6

B - Screw back in and fully tighten

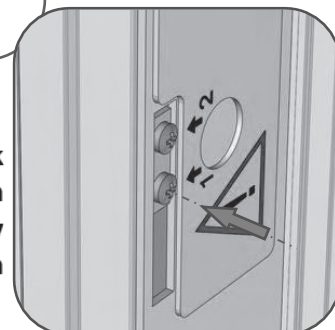

**IMPORTANT** : Place an obstacle in the wicket gate's path, to prevent its closure. Leave it there until completing the « box operation tests ».

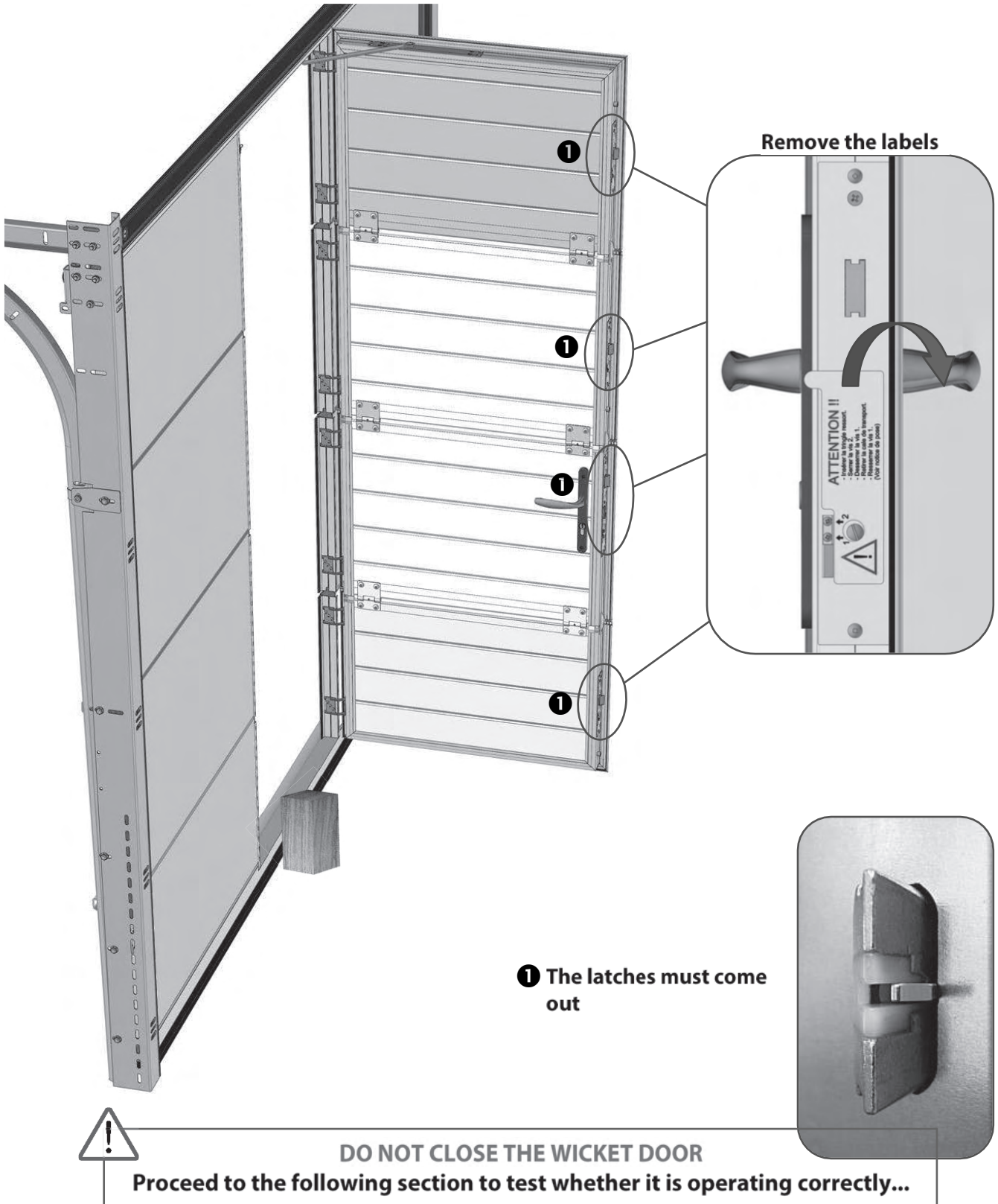

**Test 1:** For all boxes, press the release mechanism, the latches must come out at **POSITION 2**.

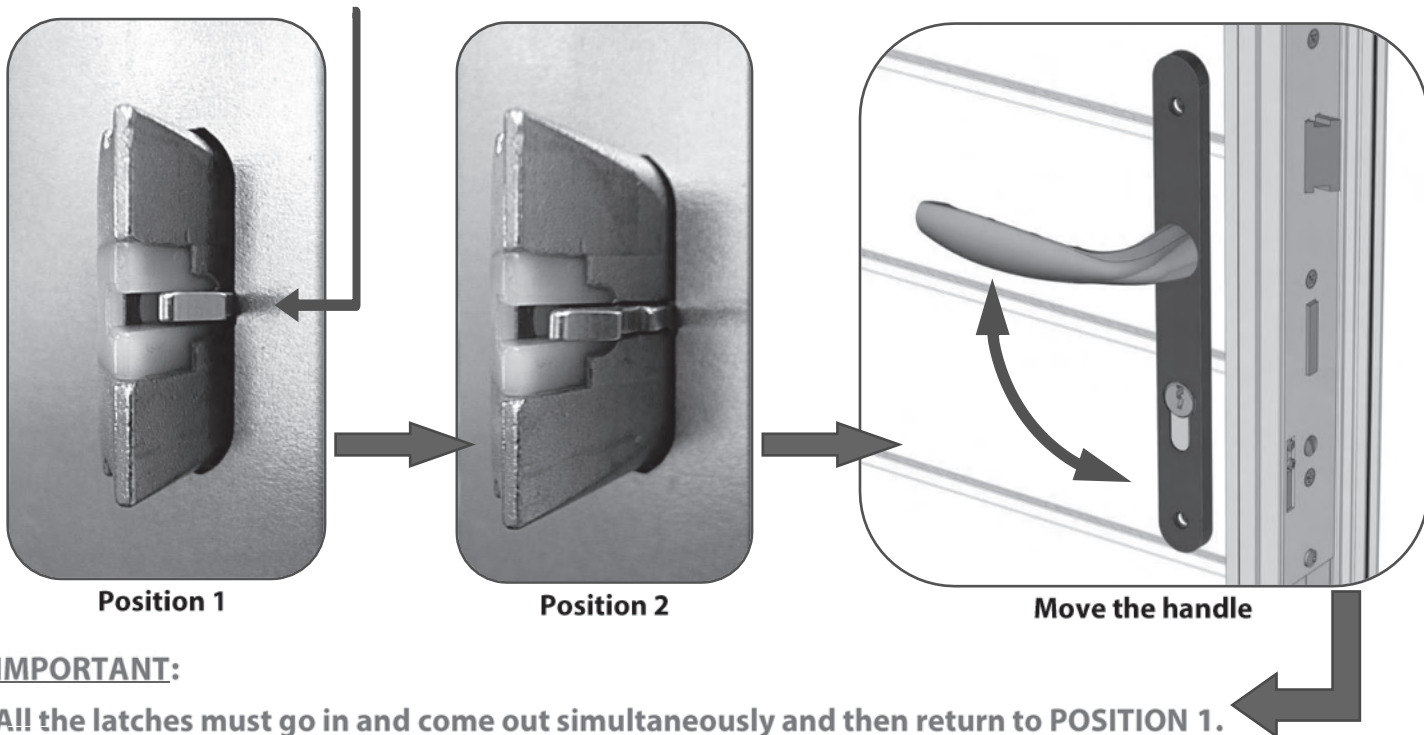

**IMPORTANT:**

All the latches must go in and come out simultaneously and then return to **POSITION 1**.

Repeat the test 2 to 3 times...

**Test 2:**



Move the handle and hold it down

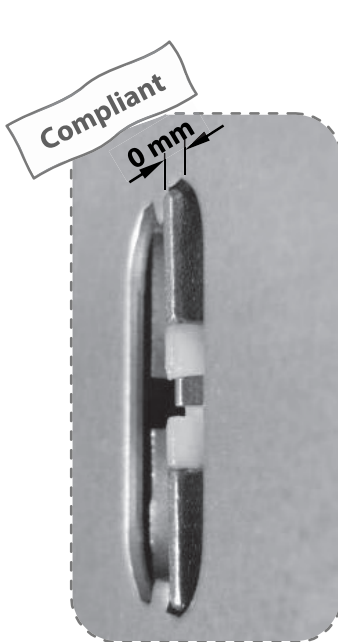

The latches must be flush

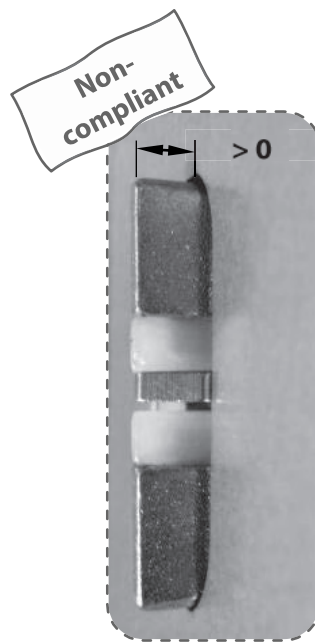

! If latch > 0 mm, go to Tip test 2

**If the latches are not all functioning correctly, do not shut the wicket door, call Customer Services.**

**IF YOU SHUT THE WICKET DOOR, IT WILL BE IMPOSSIBLE TO OPEN IT AGAIN.**

## Tip Test 2

If one or all of the latches are not flush, follow the procedure below :

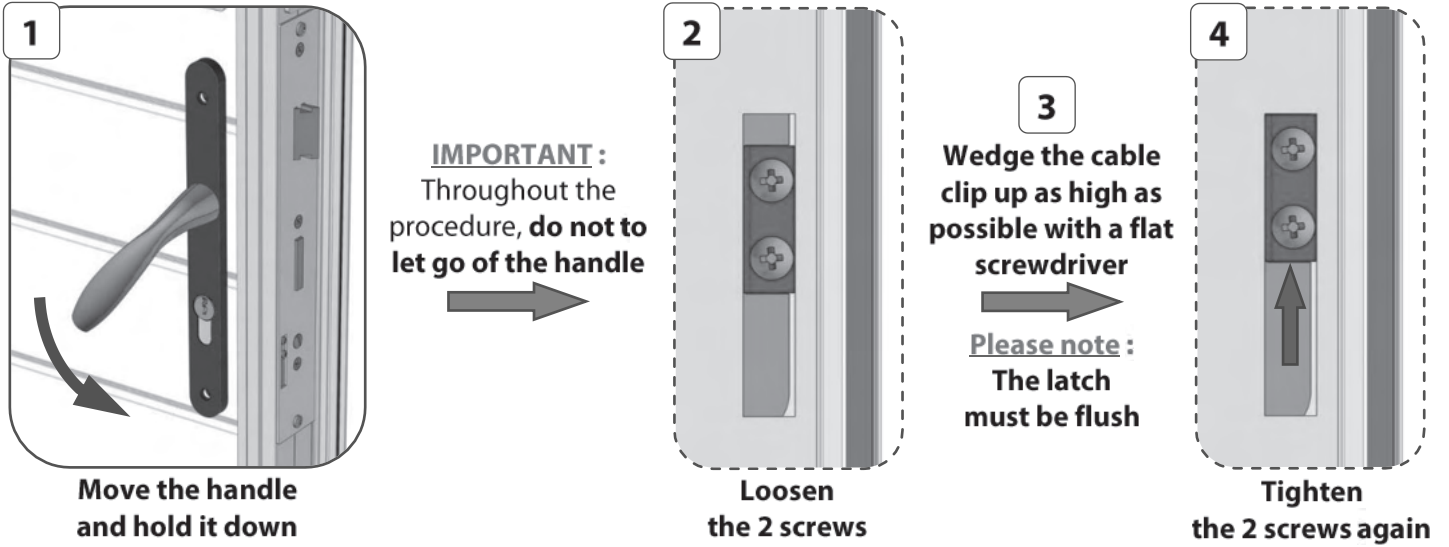

Before closing the wicket door, **check** that **the latches are flush** when holding the handle down.

**Please note :** If the **wicket door becomes stuck** after closure, refer to the “ **Solution** ” section on the following page.

If necessary, **check** and **tighten** the centralizers again.

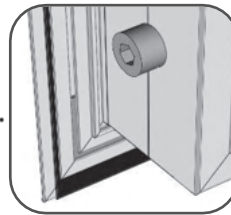

Adjusting the door closure

**Adjust the settings if necessary :**

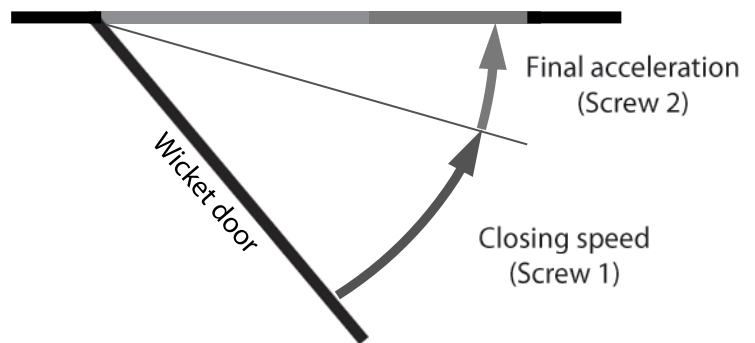
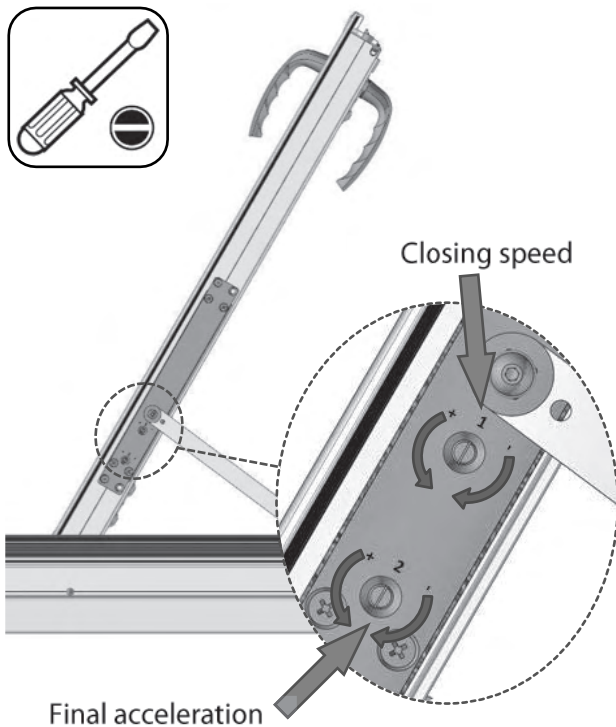

**Please note :** If there is not much space (wicket door/header) at the top, use the flat Allen key provided





Depending on the specific case, it may be necessary to cut the spring rod between the panels.

## **Identify the blocked part inside :**

Lower the handle and gently push the door on each panel to identify the blocked area.

### **Make the hook**



Actual size

### **Slide the hook into the opening of the wicket door (lock side)**

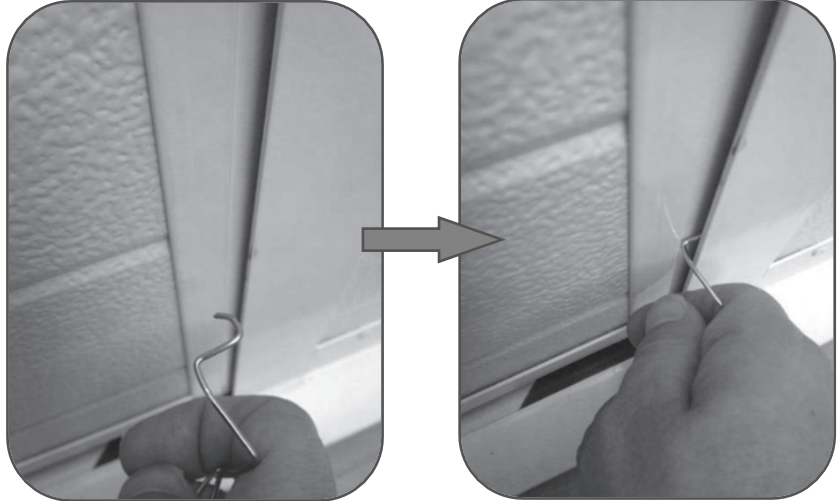

**Then carry out the steps below, to hook one of the locks while holding the handle down.**







Once open, return to the **Box operation test** chapter and **set the latches correctly by following the test steps.**

Finishes: Plugs, split hinges and strike plates

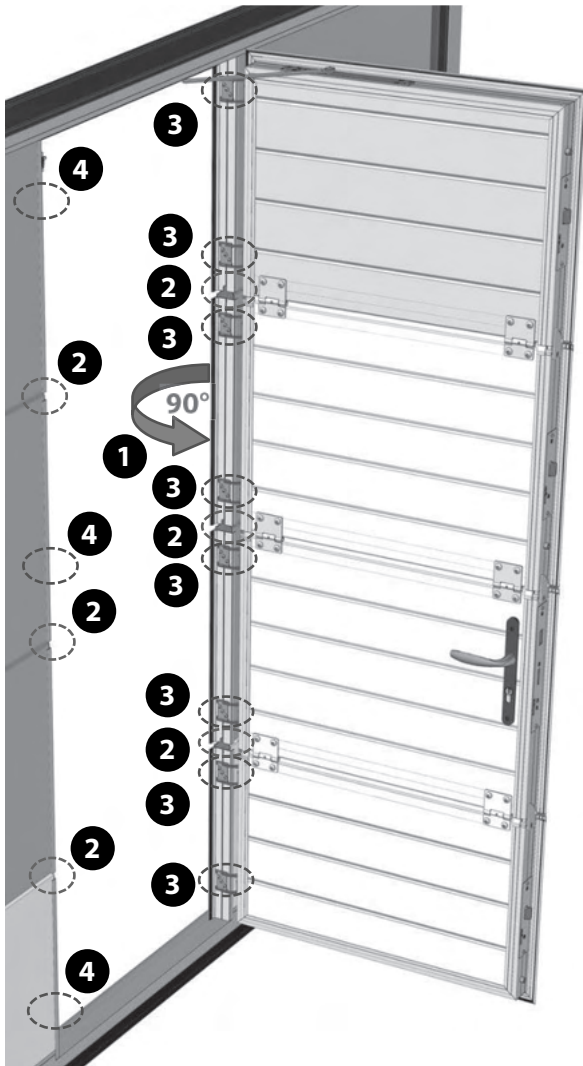

**2 PLUGS**

Assemble them on the frame

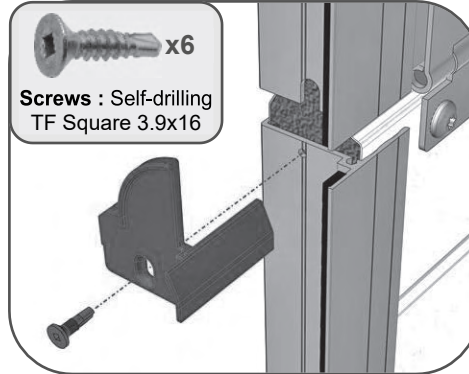

**2 SPECIFIC CASE PLUGS : Single-grooved panel**

Move the guides away slightly

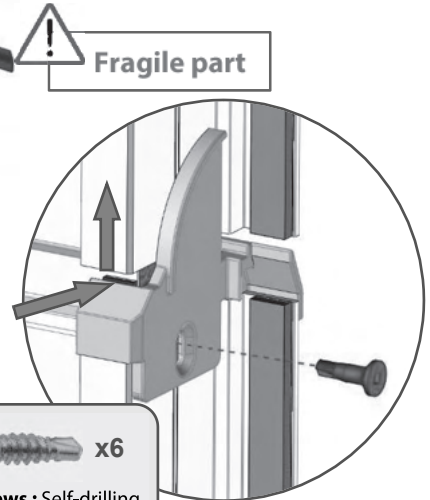

**3 SPLIT HINGES**

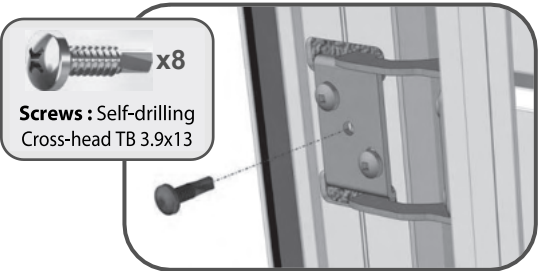

**4 STRIKE PLATES**

Tighten the screws so that the strike plates move slightly. close and reopen the wicket door; the strike plates will move into position Fully tighten the screws.

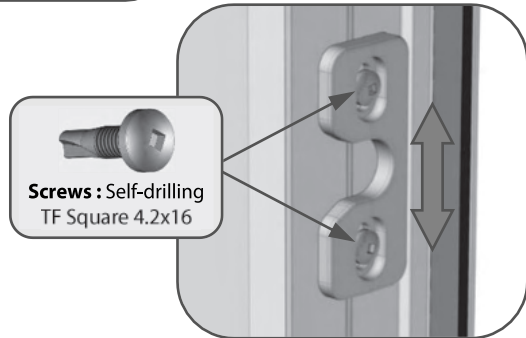

## TENSIONING THE DOOR

### Hooking the springs

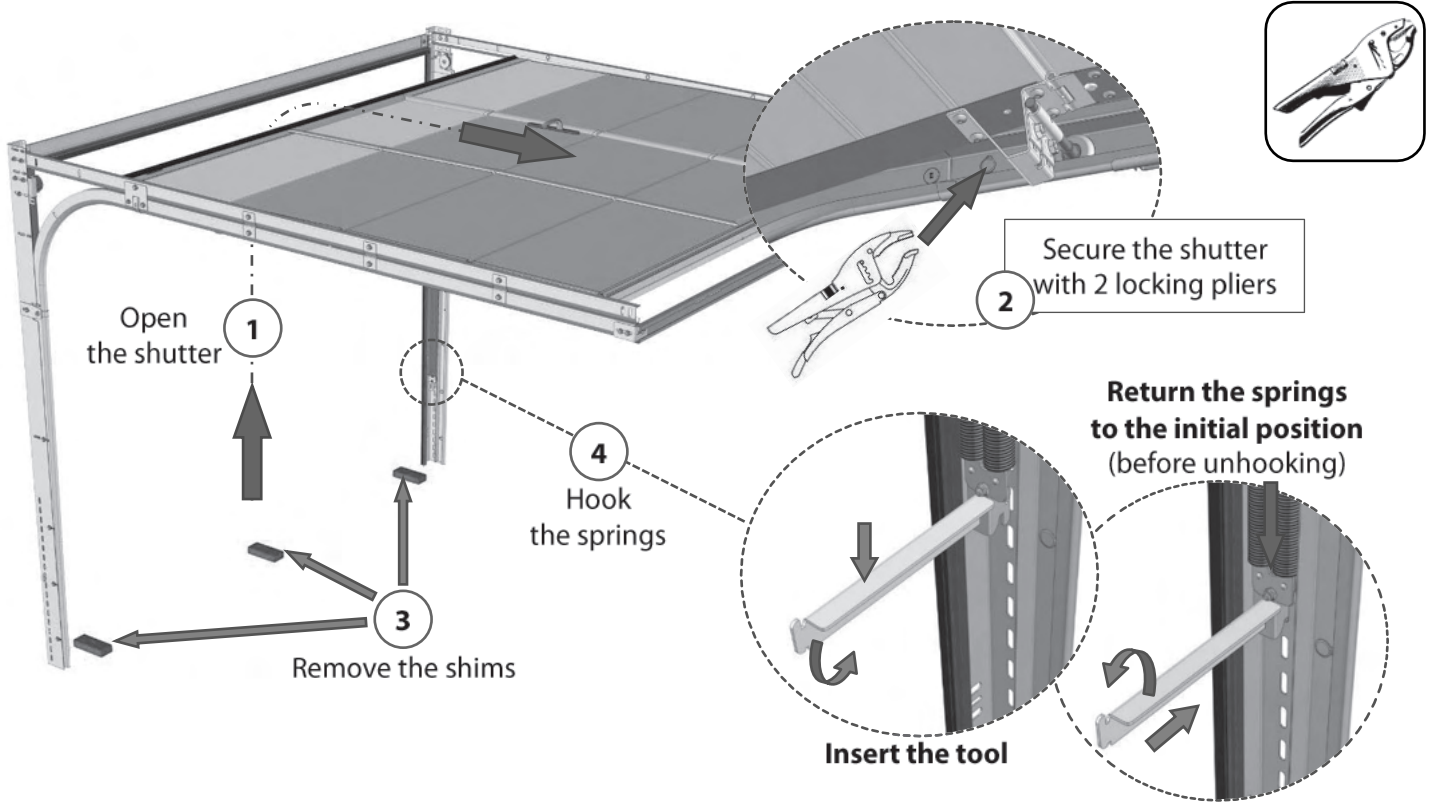

## 10. FINAL ADJUSTMENTS & OPTIONAL EXTRAS

### ADJUSTING & FIXING THE FASCIA

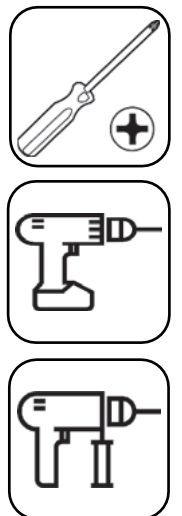
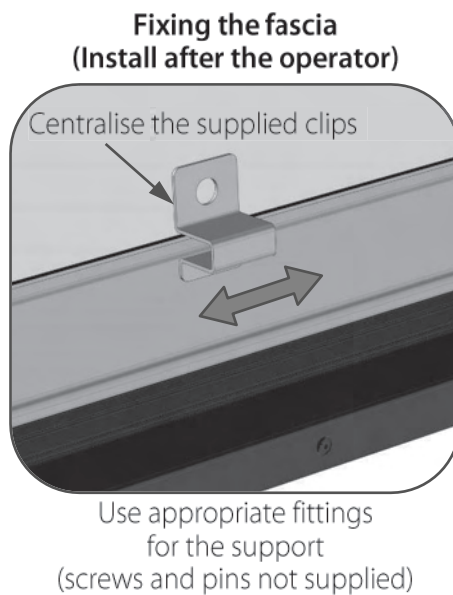
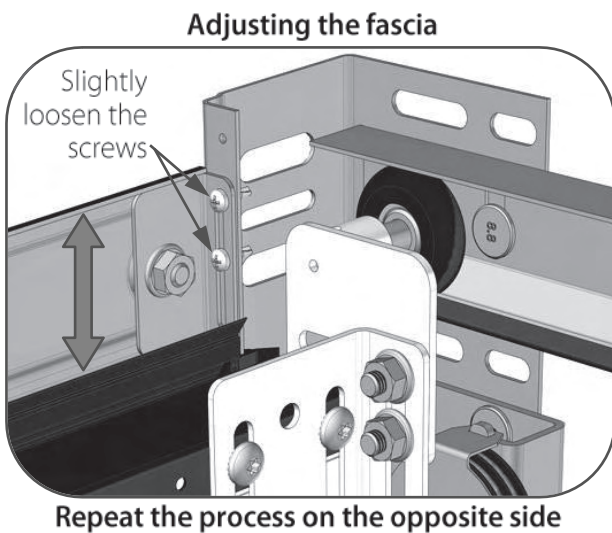

# ADJUSTING THE ROLLERS

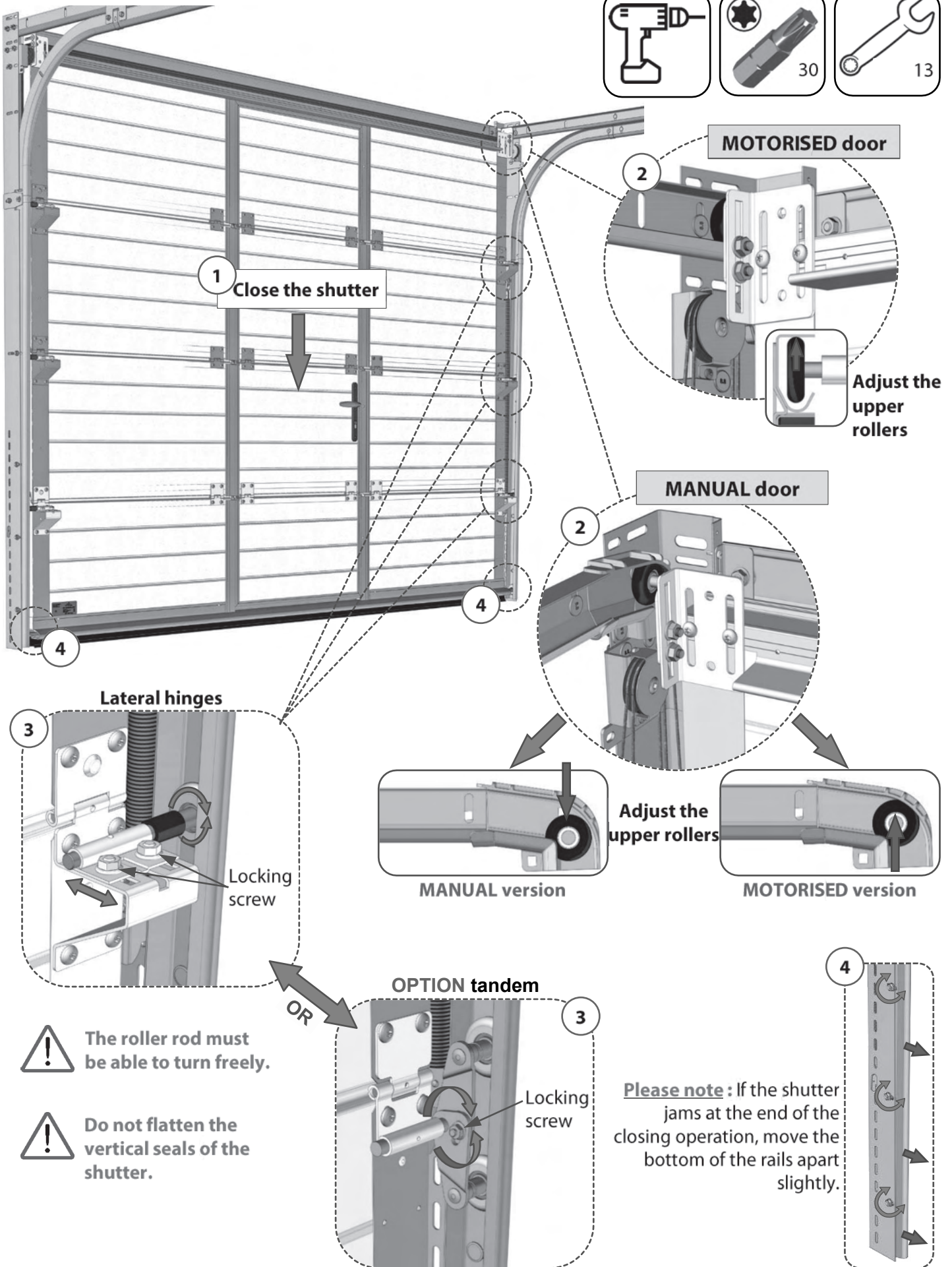

The roller rod must be able to turn freely.



Do not flatten the vertical seals of the shutter.

Checking the balance

## CHECKING THE BALANCE



Remove the **locking pliers**.

Gently close the door and **operate it several times manually**.

### **The shutter is well-balanced:**

- At mid-height, the door must be more or less stationary.  
You must be able to raise or lower it easily from this point.

### **If the shutter is not well-balanced:**

- Raise and secure the door.  
(refer to the "**Opening the door**" section).
- Tighten or loosen the springs  
(refer to the "**Adjusting the spring tension**" section).

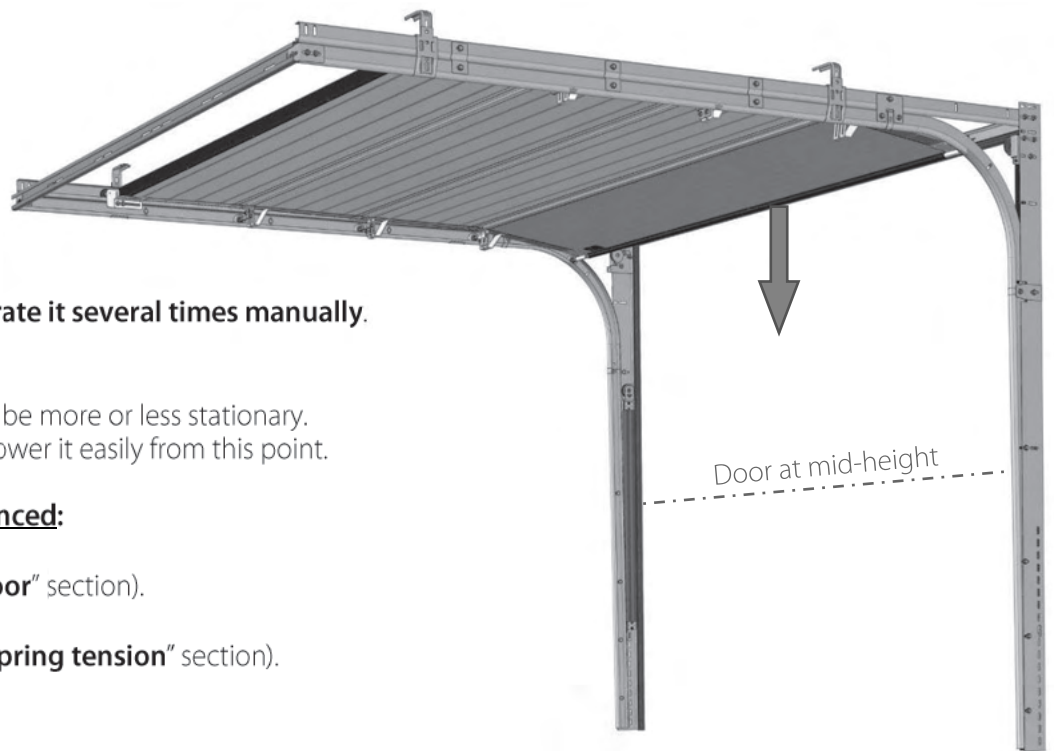

## ADJUSTING THE SPRING TENSION

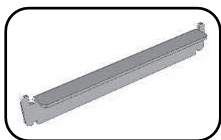

Tension  
spring  
tool

Insert the tool

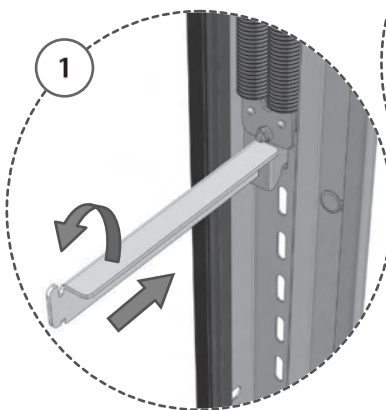

Unhook the spring

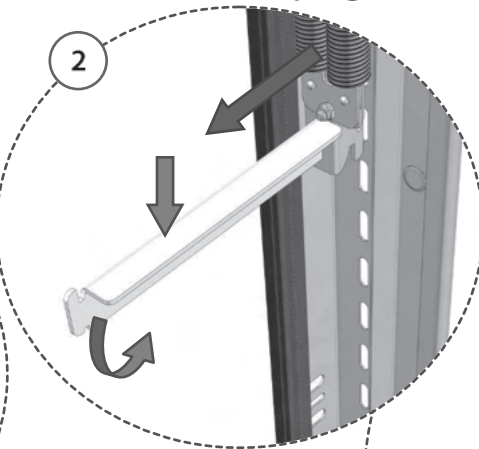

Choose a  
hooking notch

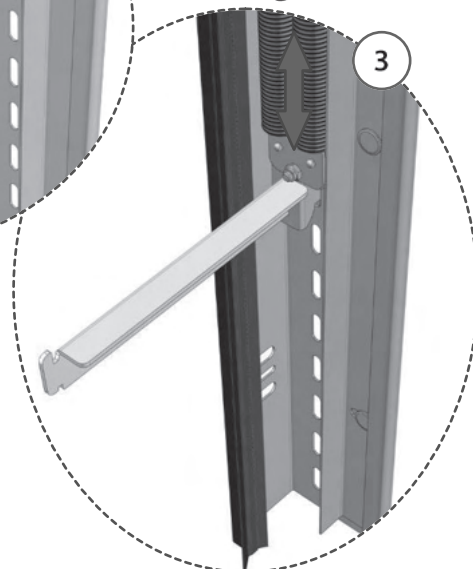

Count the notches

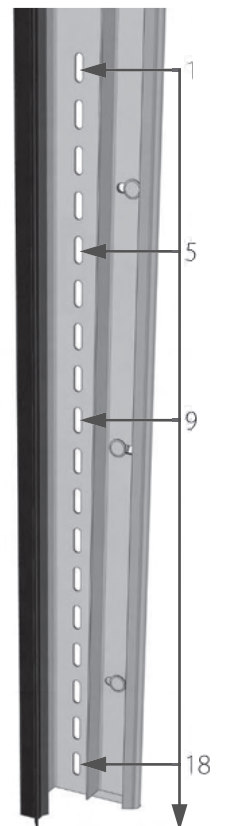

Repeat the process for the other spring.



Make sure the 2 springs are positioned on the same notch.  
Check that the spring hooks are securely fastened to the rails.

**Check the balance again:** Refer to the "**Checking the balance**" section above.

## FIXING THE UPPER ROLLER SUPPORTS

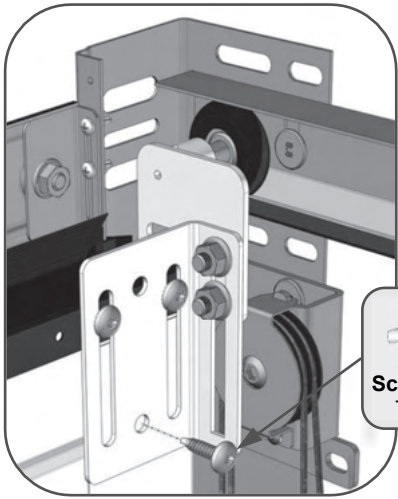

Add



x1

**Screws:** Self-drilling  
TB Torx 6.3x25

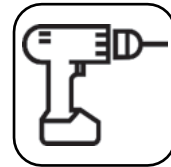

Repeat the process on the opposite side.

## FIXING THE END POSITION CLIPS (MANUAL DOOR)

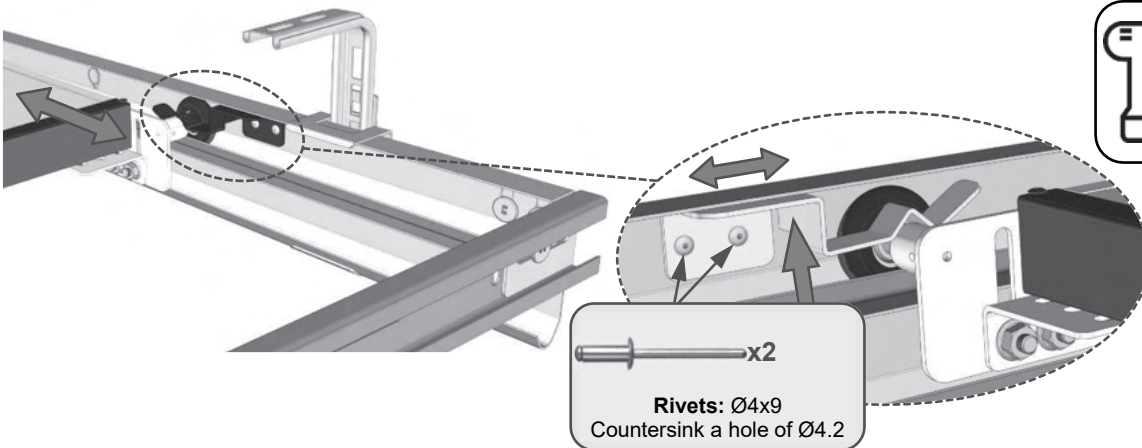

x2

**Rivets:** Ø4x9  
Countersink a hole of Ø4.2

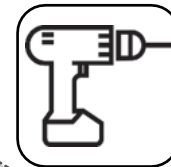

## ASSEMBLING THE HANDLES (OPTIONAL EXTRA)

On the bottom panel: Max. handle position:  $A = H / 3$

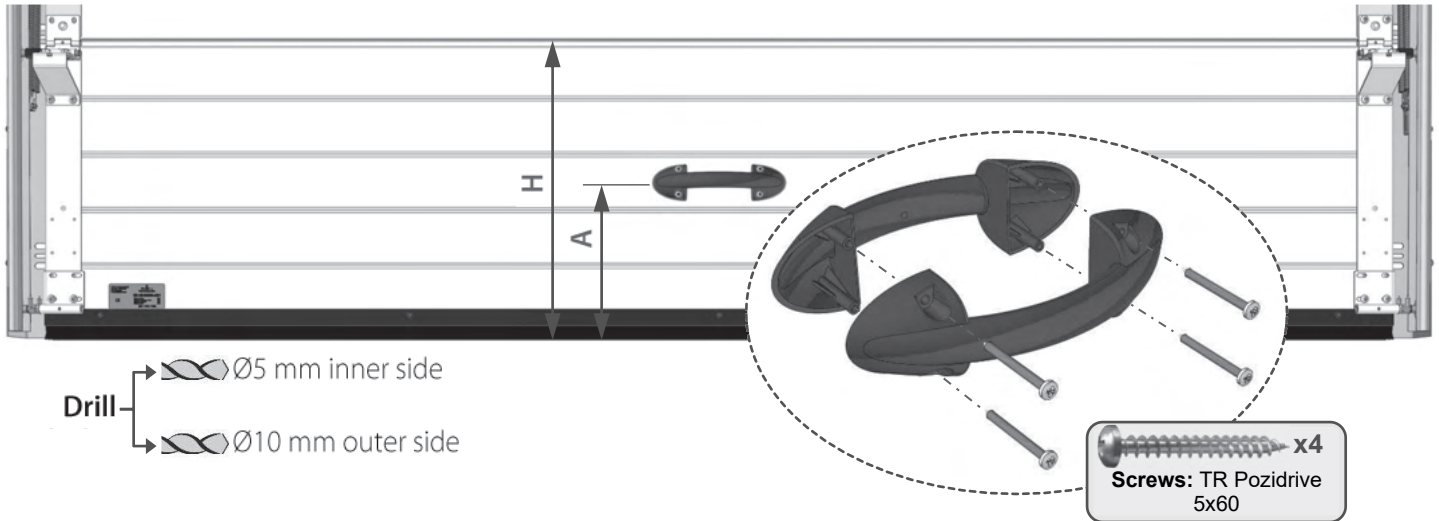

## ASSEMBLING THE SLIDE BOLT (OPTIONAL ON MOTORISED DOORS)

On 2<sup>nd</sup> middle panel:

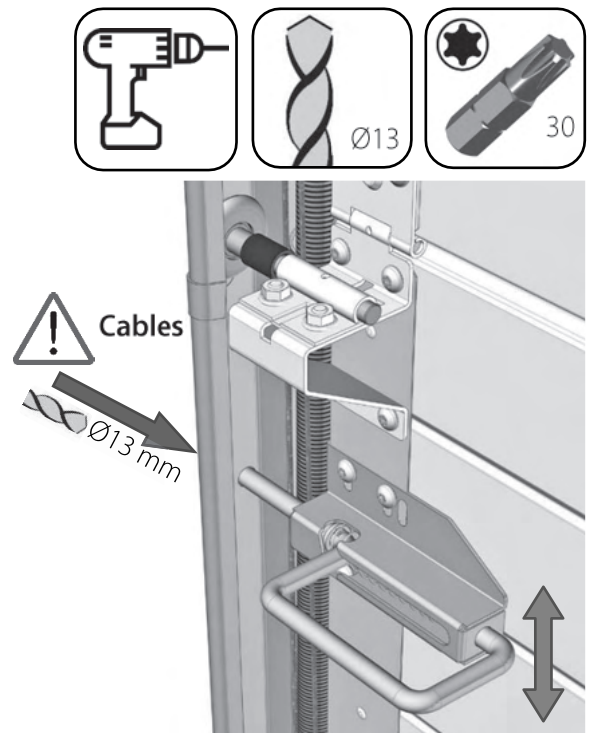
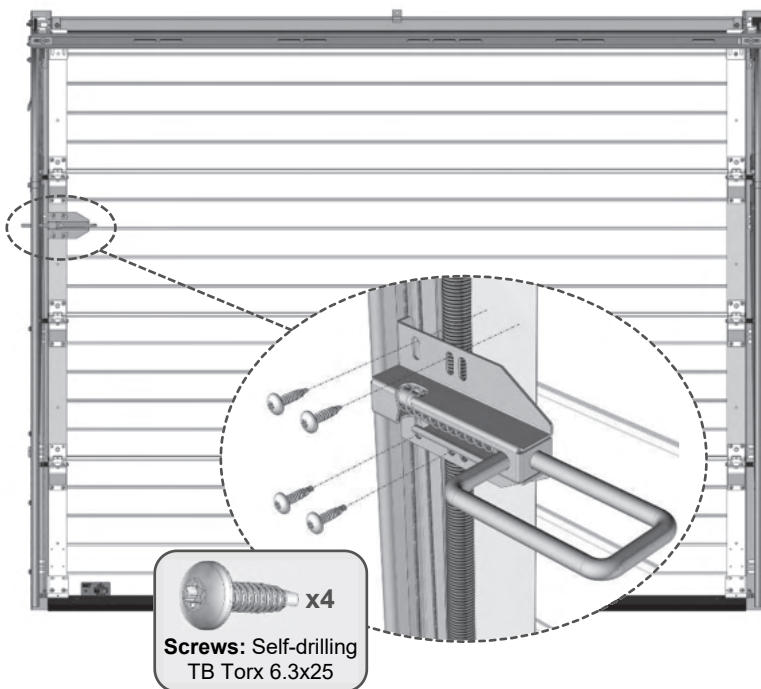

## INSTALLING THE LOCK (OPTIONAL EXTRA)

### Prepare the lock:

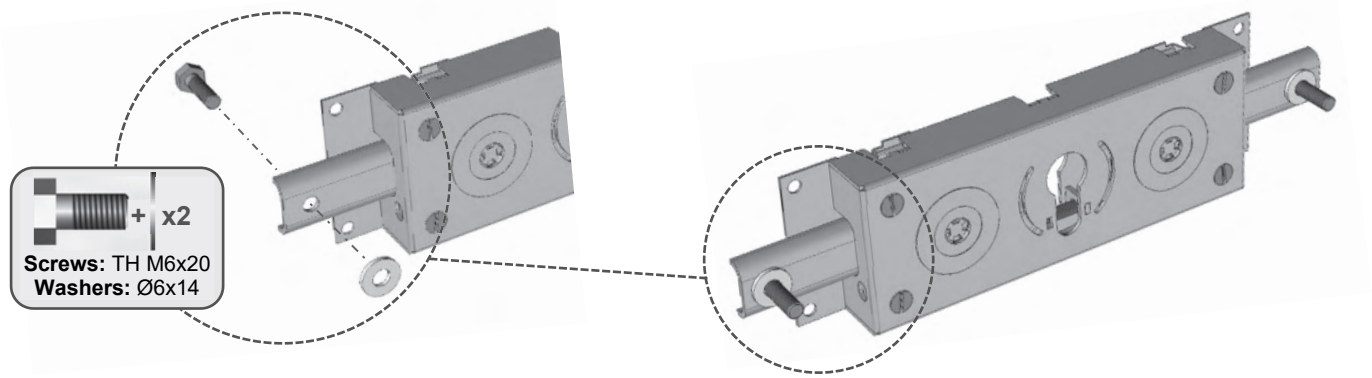

### Fixing the lock:

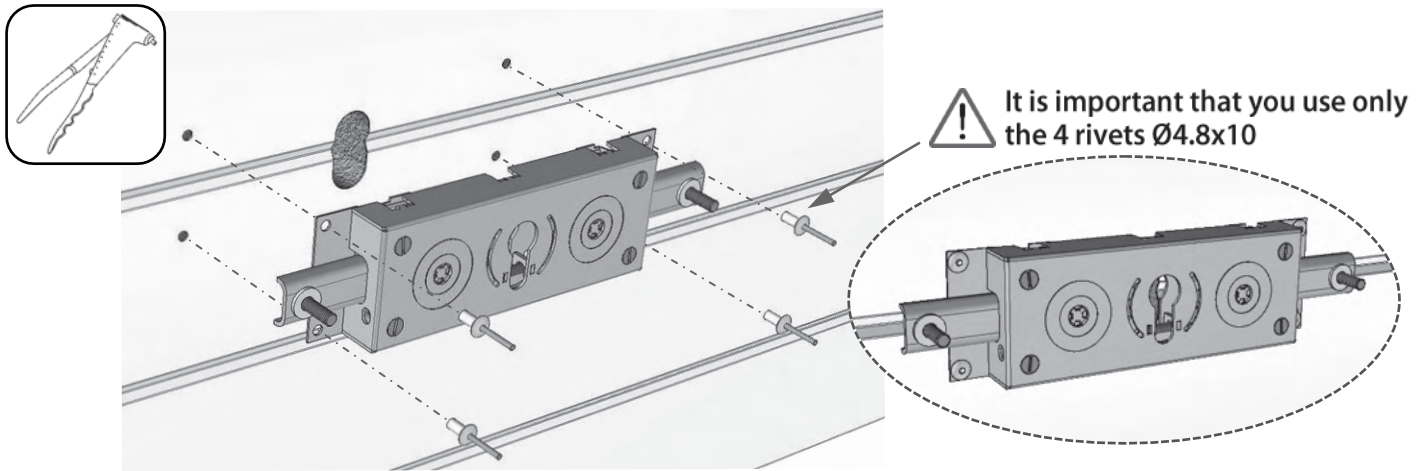

### Assembling the cylinder:

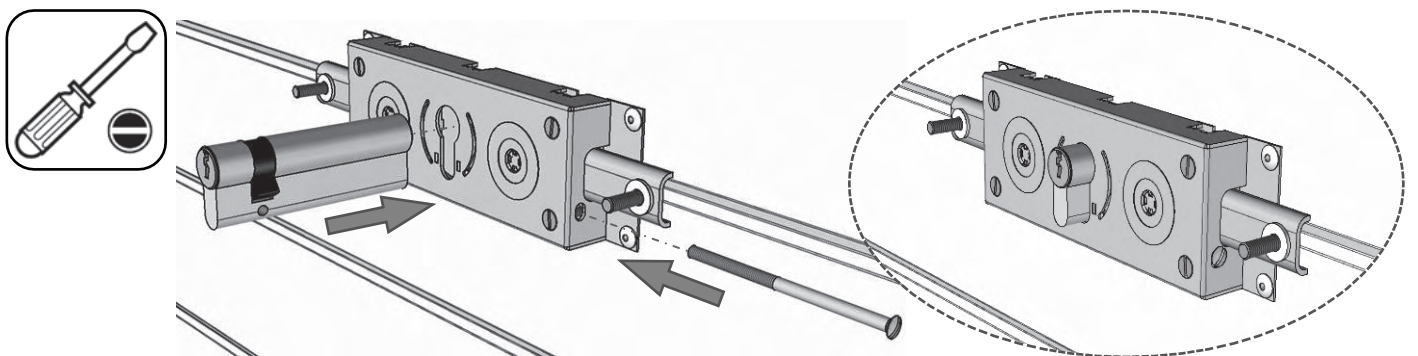

Preparing the latches (left and right):

**IMPORTANT**

Remove the springs from the left and right bolts

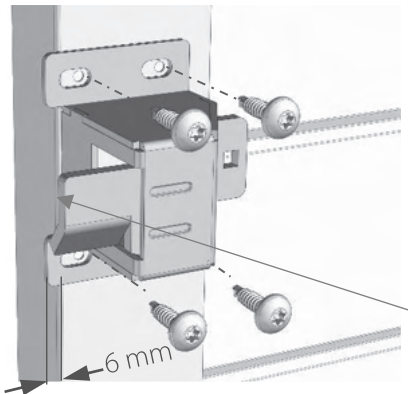
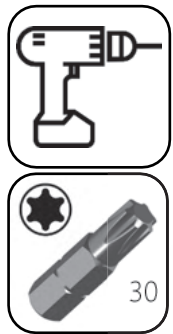
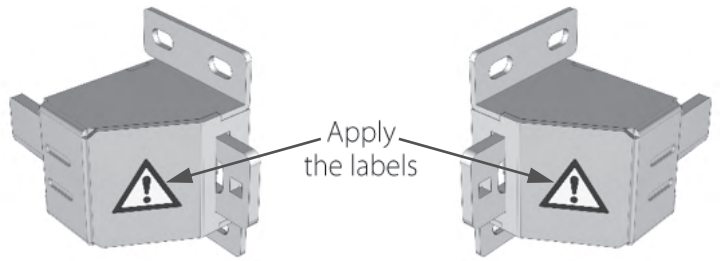
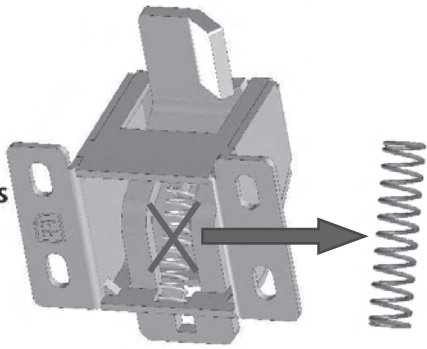

Hang the latches over the end cap by about 6mm.

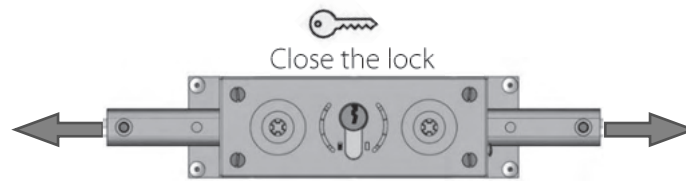
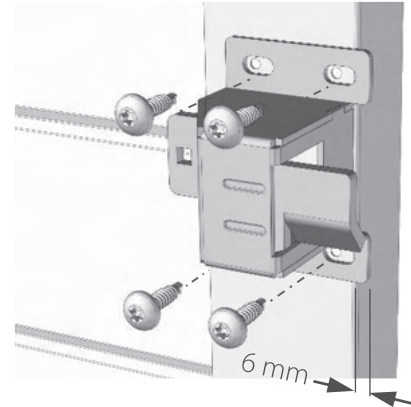



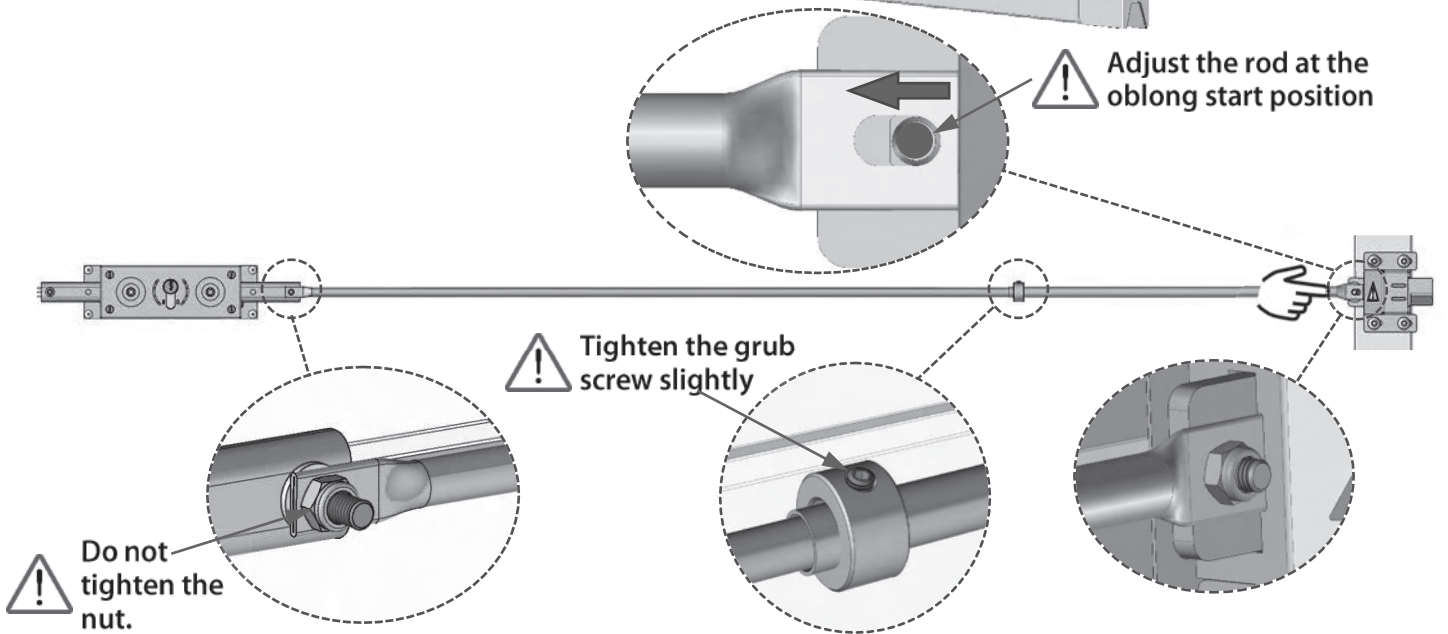
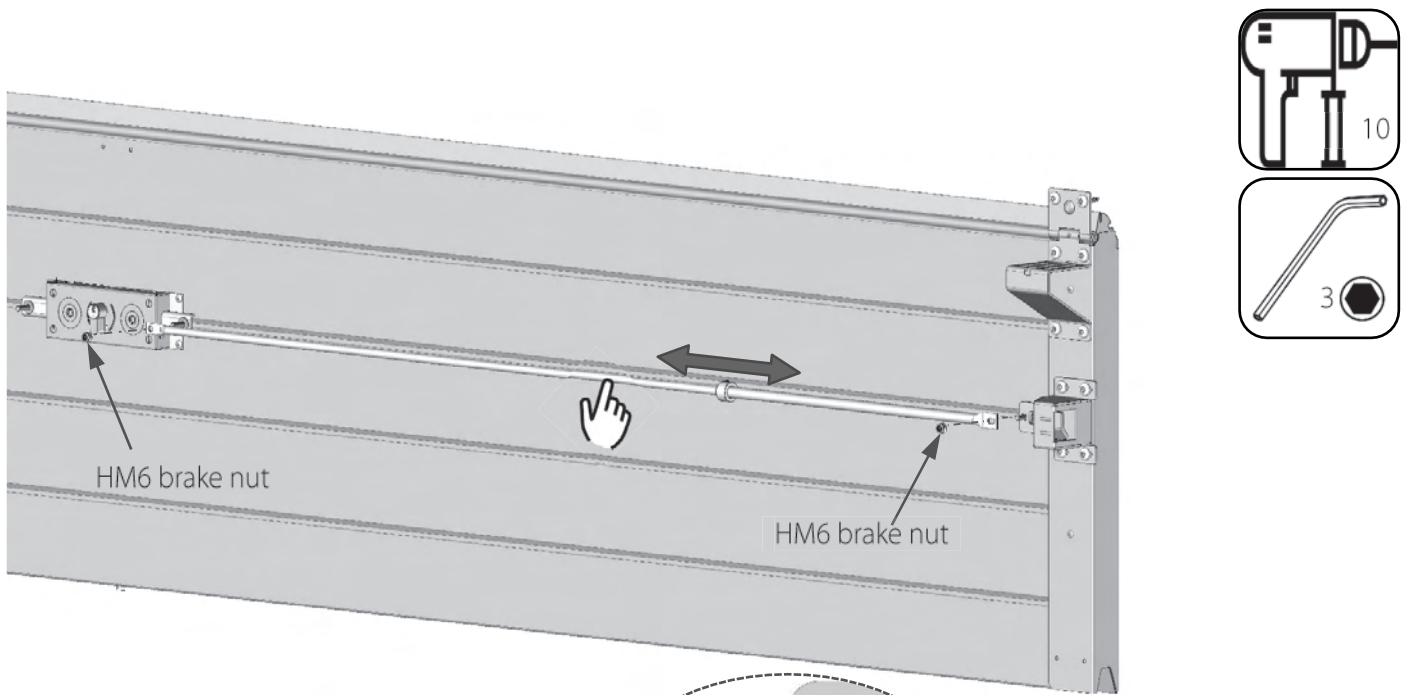

Repeat the procedure for the second rod.

## Checking the lock:

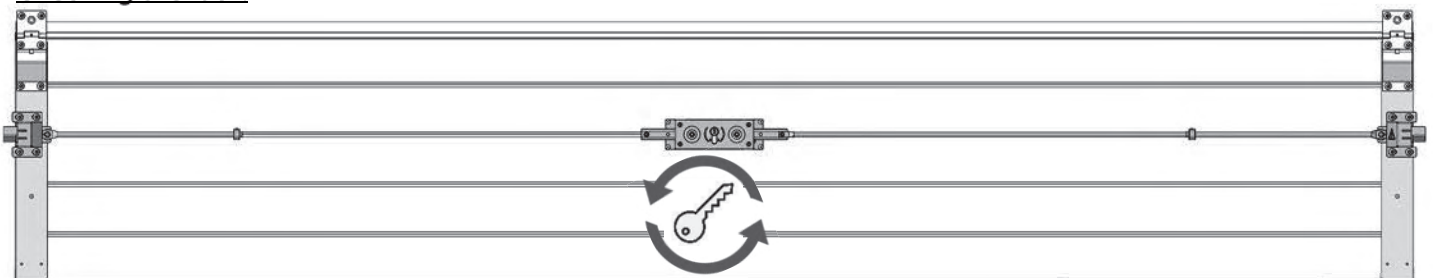

If necessary, return to the "Assembling the rods" section.

# POSITIONING THE LOCK PLATES

1- Mark out (on the 2 latches)

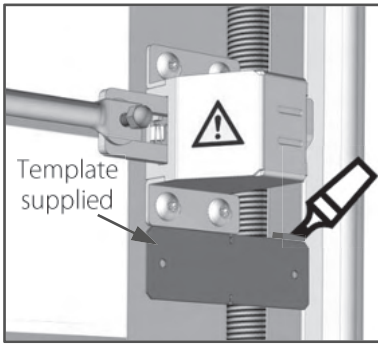

2- Open the door

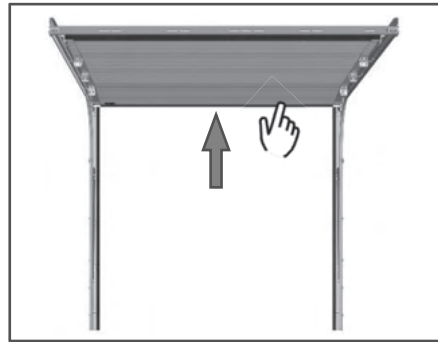

3- Offset the marking

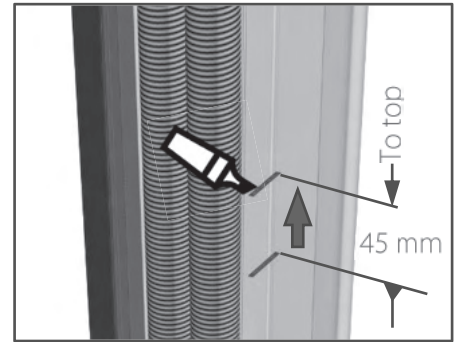

4- Position the template

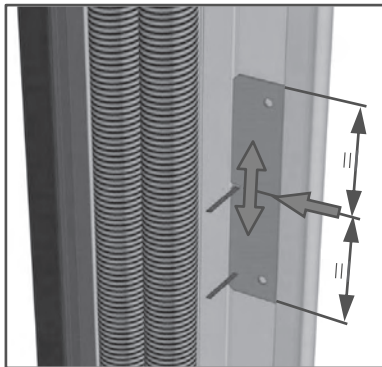

5- Mark out the drill holes

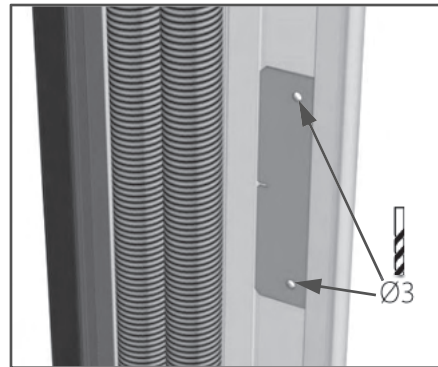

6- Drill the holes

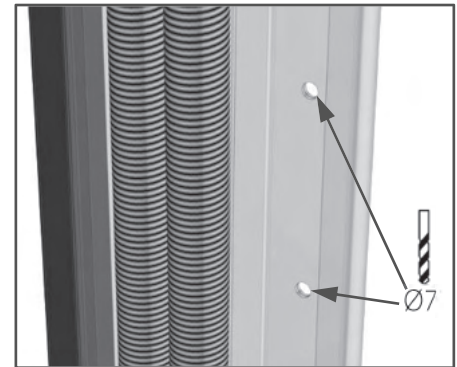

## Fixing the lock plates:

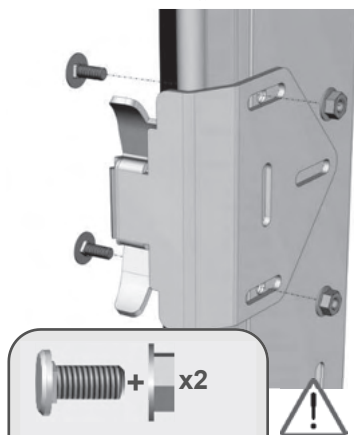

**Screws:** TRPCCM 6x16  
**Nuts:** HM 6  
 (with notched base)

**Do not fully tighten the nuts.**

Close the door

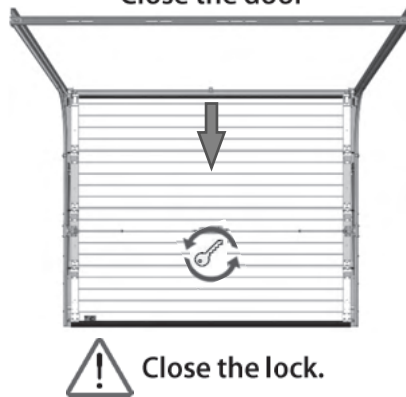

**Close the lock.**

Adjust the lock plates

Tighten the nuts after adjusting

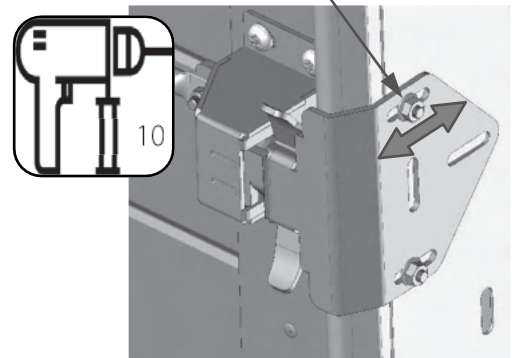

**Allow some play between the strike plate and the latch.**

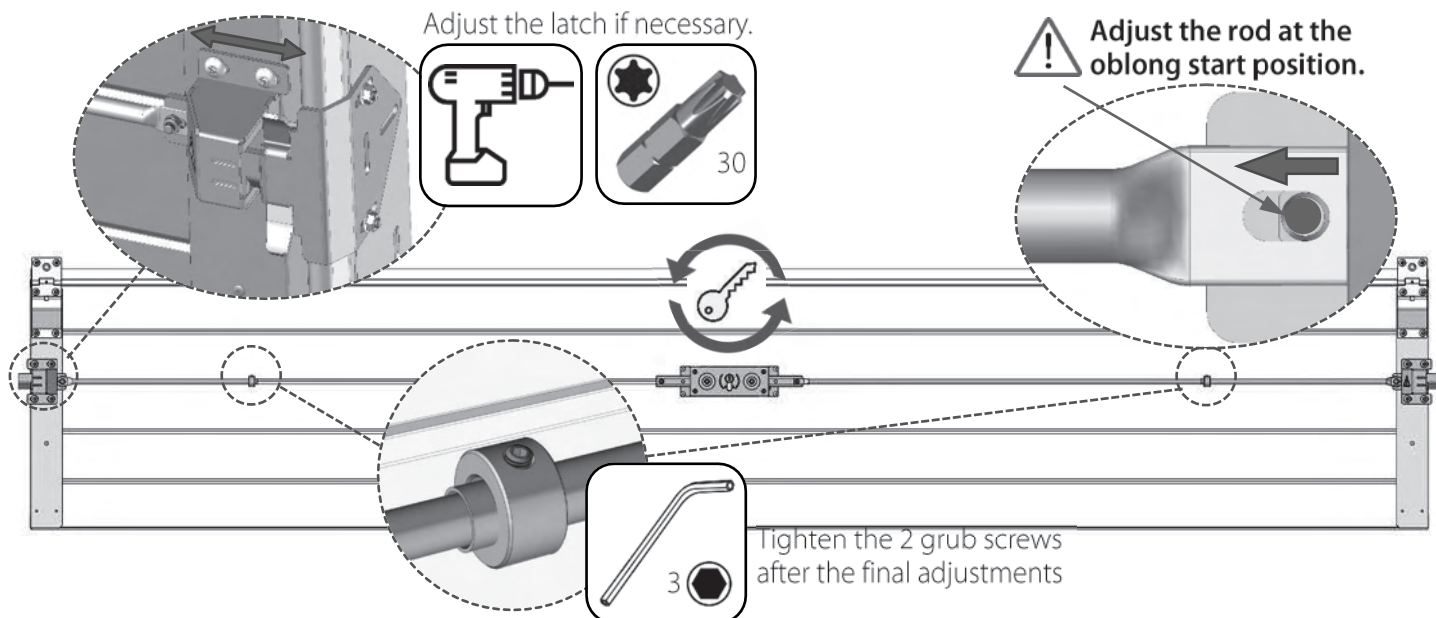

**Lightly grease the lock and the 2 latches:**

Lock

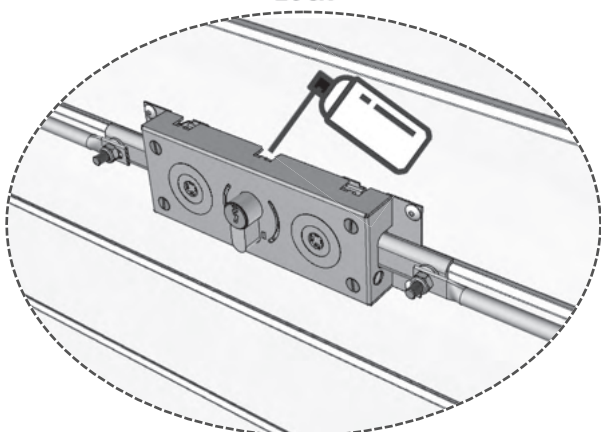

On the latches

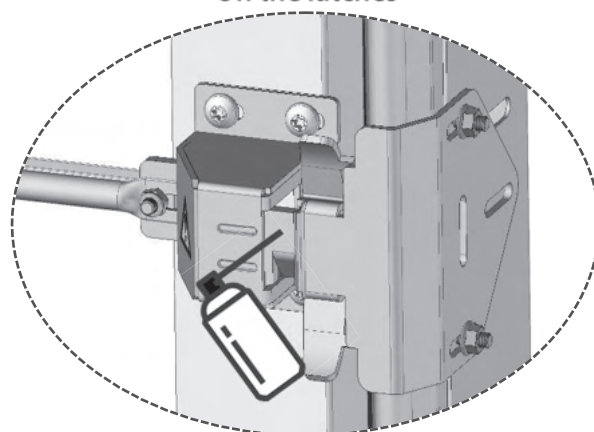

**IMPORTANT:**

If you feel a rough spot, check the installation of the latches, rods and locking plates.

**Fixing the cover plate:**

Drill the panel

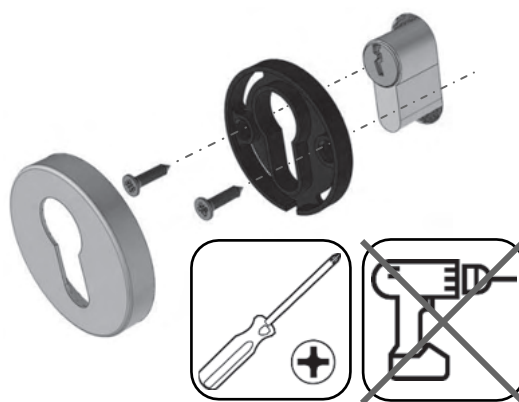
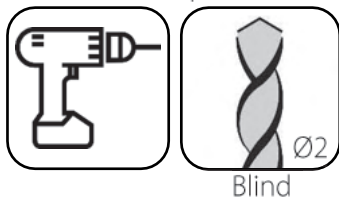

## INSTALLING THE PULL CORD (MANUAL DOOR)

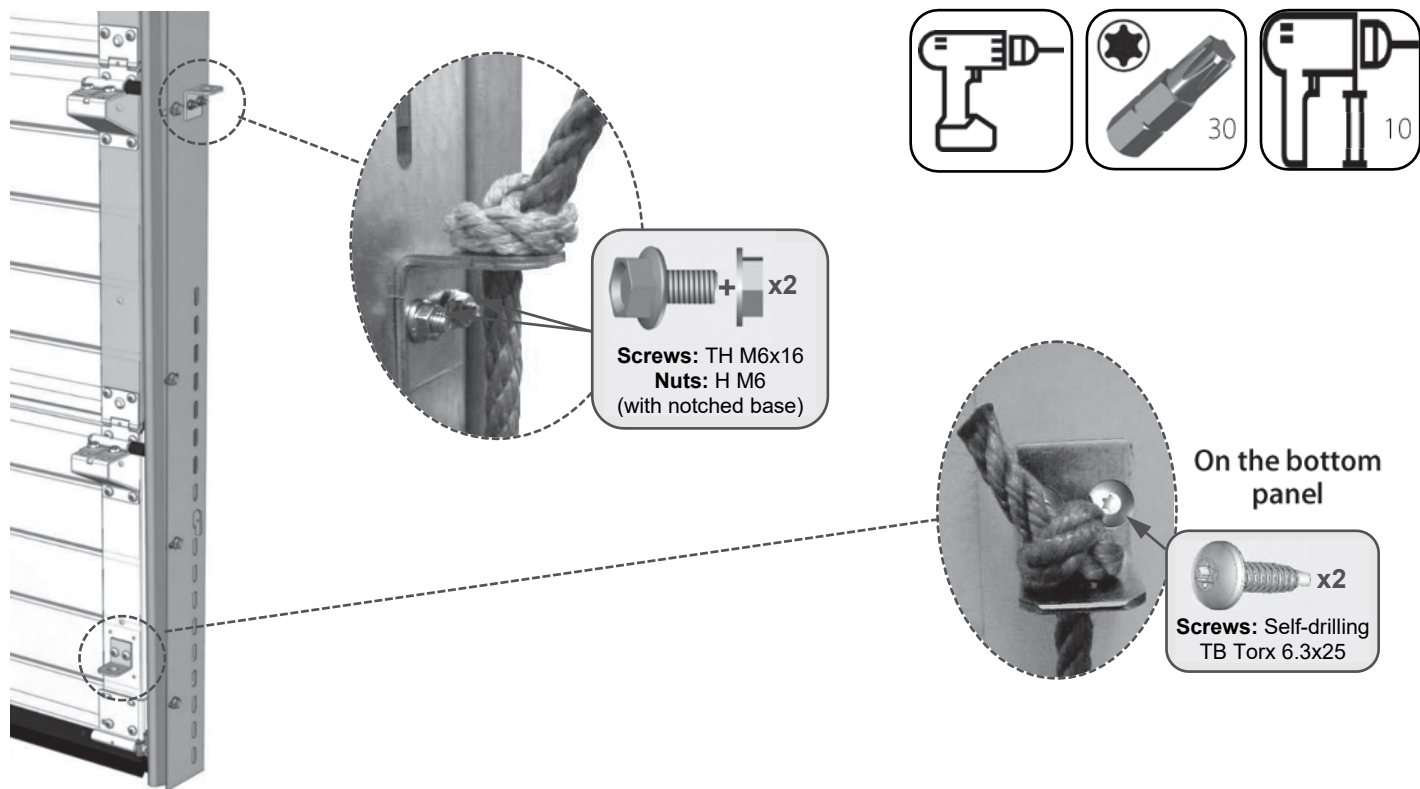

## SECEUROSEAL WEATHER SEAL (OPTIONAL)

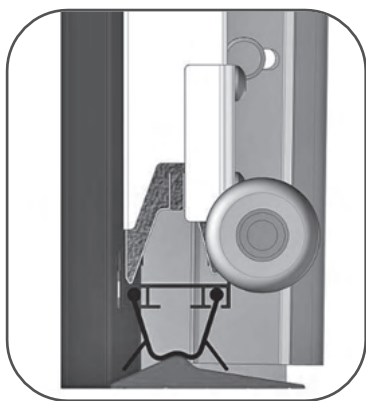

Weather seal section  
to be glued to the floor between the rails.

Refer to SeceuroSeal Installation Instructions.

## ASSEMBLING THE SPRING PULLEY COVERS (OPTIONAL)

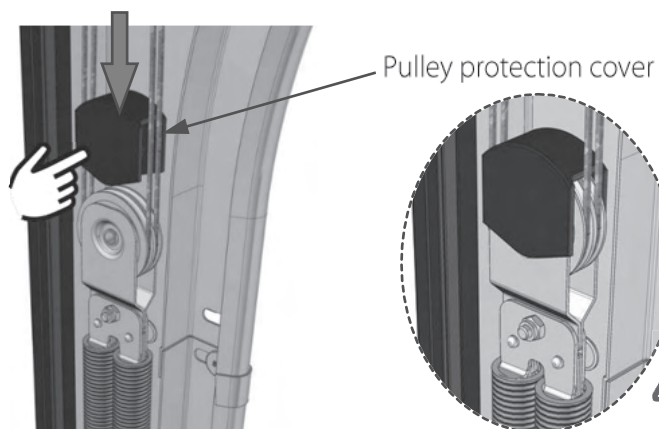

Pulley covers are not supplied if the rails are equipped with the protection cover option.

## REMOVING THE COVER LABELS



Remove the cable labels

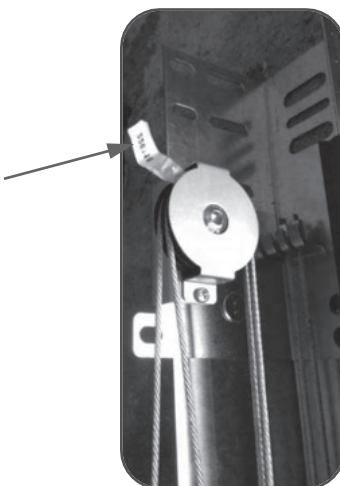

### [1] Releasing the motorisation

Pull on the cord until door drive system is released.

### [2] Manual manipulation of the door

This is possible as the drive system is released.

### [3] Re-engaging the motorisation

Move the door manually until the drive mechanism re-locks on the transmission rail.

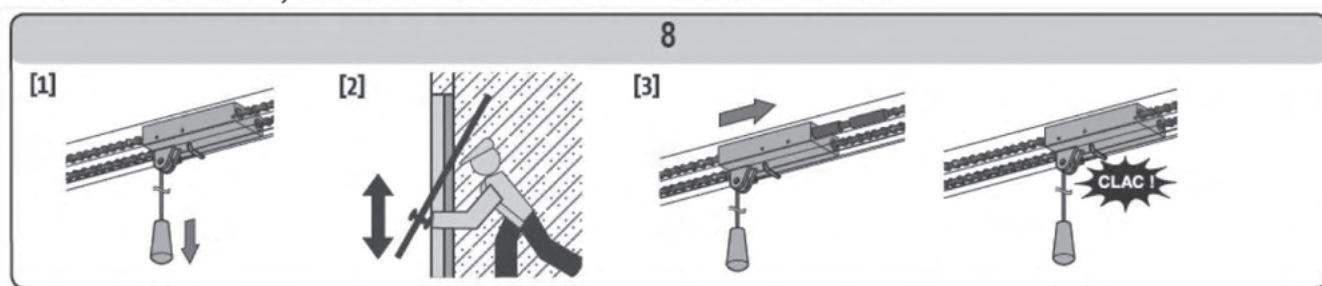

When releasing the motorisation, sudden movements may occur if the door is incorrectly balanced which may be dangerous. Only use the cord to release the motorisation. Never use the cord to manipulate the door manually. It is essential that the motorisation is re-engaged before any new commands.

## 11. SET THE LIMITS

- i. Instructions on how to set up the operator and the door's limits are provided in the accessory box, you can also access them digitally using this QR code or link: [www.sws.co.uk/fitting-instructions](http://www.sws.co.uk/fitting-instructions)



## 12. COMMISSIONING

### Final Checks

- i. Remove any protective plastic coverings.
- ii. Wipe panels with damp cloth.
- iii. Touch-up any small scratches.
- iv. Check all electrical & operating equipment is installed and functioning correctly and complete UKCA marking label and paperwork.

**N.B.** Check the front of the panels to make sure that it is not rubbing on the lintel.

This will take a few moments to occur.

If you wish to demonstrate how to operate the door manually immediately after opening the door press either the stop button on the handset or simulate a power cut by switching off the power to the operator.

**Upon completion it is your responsibility to train the customer how to operate the door correctly and safely and provide them with the operating and maintenance instructions supplied.**

## 13. TECHNICAL ASSISTANCE

If you require any on site technical assistance including repair or maintenance queries please call 01524 772400 or email [technical@swsuk.co.uk](mailto:technical@swsuk.co.uk).